



**Istruzioni per l'uso**  
*Instructions for use*  
*Instructions d'utilisation*  
*Gebrauchsanweisung*  
*Instrucciones de uso*

**CONTAMETRI** \_\_ pagina 3

*CHAIN COUNTER* \_\_ page 26

*COMPTEUR MÉTRIQUE* \_\_ page 49

*METERZÄHLER* \_\_ Seite 72

*CUENTAMETROS* \_\_ página 95



**EV-030**

Rev. 07 – 2008

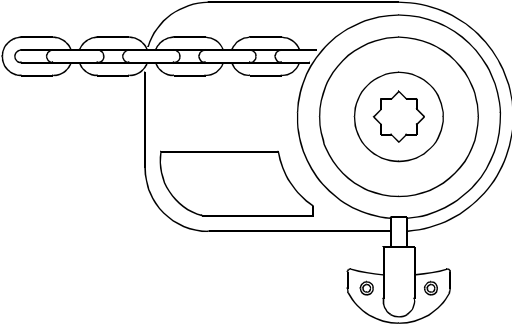

**Fig. 1A**

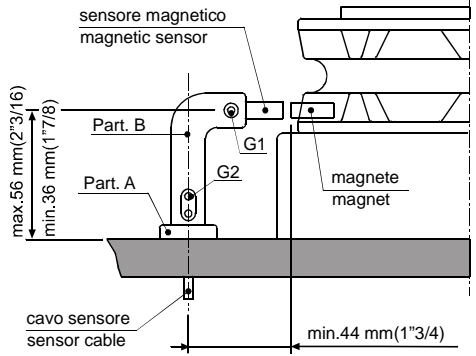

**Fig. 1B**

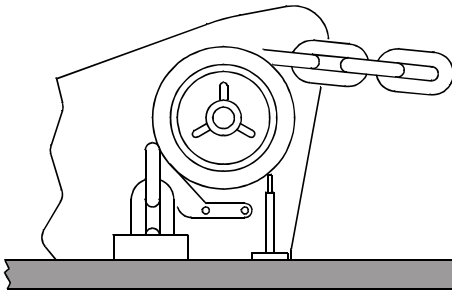

**Fig. 2A**

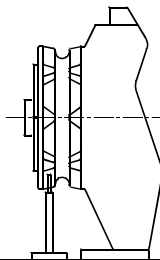

**Fig. 2B**

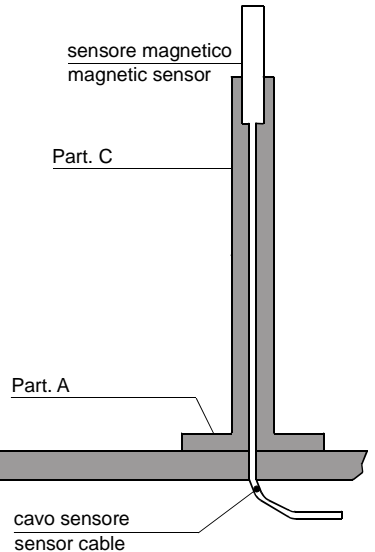

**Fig. 2C**

## Descrizione

Il contametri **EV-030** permette di salpare o calare un'ancora con la visualizzazione dei metri o piedi di catena svolta e della velocità della stessa.

## Dati tecnici

Tensione di alimentazione	da 10 a 30 V DC
Assorbimento di corrente	min. 5 mA – max 40 mA
Grado di protezione involucro parte frontale	IP65*
Temperatura operativa	0 / +70 °C (32 / 158 °F)
Display grafico	128 x 64 pixel
Misura massima raggiungibile	999 metri – 999 piedi
Dimensioni (mm)	100 x 100 x 32**
Peso (g)	160

\* esclusa la zona di connessione dei cavi - \*\* senza coperchio di protezione



### **Attenzione**

**ALIMENTARE ESCLUSIVAMENTE IN CORRENTE CONTINUA.**

## Note generali

Il contametri **EV-030** deve essere utilizzato per gli scopi descritti in questo manuale – azionamento e visualizzazione dei metri/piedi di catena svolti da un salpa ancora. Qualunque altro utilizzo è da ritenersi un uso improprio.

**La manomissione dello strumento provoca il decadimento immediato della garanzia.**

## Componenti

### La confezione contiene:

- contametri, guarnizione e coperchio di chiusura;
- connettore maschio a dieci poli con 10 contatti maschio a crimpare;
- sensore magnetico;
- kit supporto (supporto del sensore per salpa ancora ad asse verticale, base di supporto, 2 viti di fissaggio, guarnizione OR);
- magnete;
- supporto sensore per salpa ancora ad asse orizzontale;
- istruzioni per l'uso.

## Installazione

**Su alcuni modelli di salpa ancora il sensore ed il magnete sono stati già installati (predisposizione contametri) non è quindi necessario eseguire le operazioni indicate di seguito.**

### Installazione del magnete sul salpa ancora

- Il foro da praticare su un dente del barbotin - del diametro di 6,5 mm (~1/4") e della profondità di 8 mm (5/16") - deve trovarsi in una zona non interessata dal passaggio della catena.
- Per i salpa ancora ad asse verticale (vedi Fig. 1B) eseguire la foratura nella circonferenza inferiore del barbotin.
- Per i salpa ancora ad asse orizzontale (vedi Fig. 2B) eseguire la foratura sulla circonferenza esterna del barbotin.
- Verificare, inoltre, che la parte sporgente del magnete, durante la rotazione del barbotin, non urti contro la base o il sensore.
- Inserire il magnete, nel foro, dalla parte metallica lasciando sporgere la parte protetta di circa 2 mm. Fissarlo utilizzando un collante per metalli (colla epossidica bi-componente) o silicone. Il collante utilizzato deve essere resistente all'ambiente marino.

## Montaggio sensore magnetico per salpa ancora ad asse verticale

(vedi Fig. 1A – 1B)

- Praticare nella coperta un foro del diametro di 4 mm (~3/16") per il passaggio del cavo del sensore.
- Fissare il Part. A del supporto, con le due viti a corredo, dopo avere posizionato nella parte inferiore dello stesso la guarnizione OR.
- Inserire il Part. B, con il sensore magnetico, sul supporto A e regolarlo in altezza in modo che si trovi in asse con il magnete fissato sul barbotin.
- Avvicinare il sensore a circa 3 mm (~1/8") dal magnete e fissarlo serrando la vite G1. Serrare successivamente la vite G2.

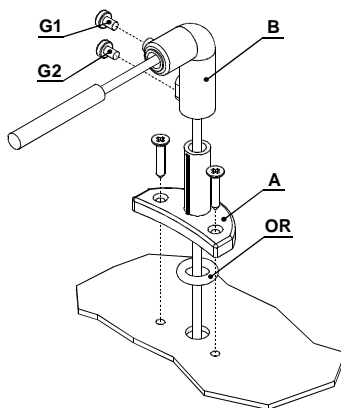

## Montaggio sensore magnetico per salpa ancora ad asse orizzontale

(vedi Fig. 2A – 2B – 2C)

- Praticare nella coperta un foro del diametro di 4 mm (~3/16") per il passaggio del cavo del sensore.
- Fissare il Part. A del supporto, con le due viti a corredo, dopo avere posizionato nella parte inferiore dello stesso la guarnizione OR.
- Tagliare, con un seghetto, a misura il Part. C. Il sensore deve essere posizionato a circa 3 mm (~1/8") dal magnete.
- Inserire il Part. C, con il sensore magnetico, sul supporto A e fissarlo utilizzando un collante per materiali plastici (colla epossidica bi-componente) o silicone.
- Fissare, con lo stesso collante, il sensore al Part. C.

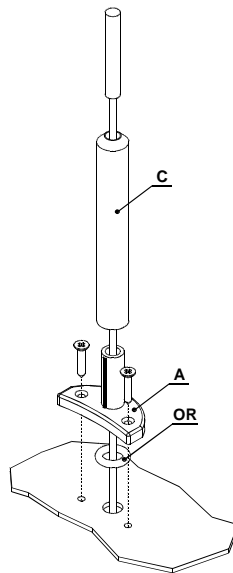

## Installazione contametri

(vedi schema elettrico)



### Attenzione

**STACCARE SEMPRE LA BATTERIA PRIMA DI PROCEDERE ALL'INSTALLAZIONE.**

- Il contametri deve essere posizionato in modo che il display sia facilmente leggibile e non esposto ai raggi solari.
- La parte posteriore del contametri deve essere protetta dal contatto di acqua o di umidità.
- Lo strumento può essere fissato su plance di qualsiasi spessore. Le viti per il fissaggio devono essere autofilettanti con un diametro di 3,5 mm (~9/64") e aventi una lunghezza massima pari a 10 mm più lo spessore della plancia.
- Nella parte posteriore, alla plancia, vi deve essere uno spazio minimo pari a 35 mm (~1"3/8). Inoltre, deve essere presente un accesso per l'installazione e la manutenzione.
- Sulla plancia praticare un foro del diametro di 30 mm (~ 1" 3/16), come indicato, e 4 fori da 4 mm (~5/32") per le viti di fissaggio del contametri. Tagliare con un tronchese i tre piolini posti sul lato posteriore dello strumento, posizionare il contametri e fissarlo alla plancia serrando le quattro viti. Qualora sulla plancia sia già presente un foro da 54 mm (2"1/8) non occorre tagliare i piolini posteriori.
- La guarnizione deve essere interposta tra il contametri e la plancia.

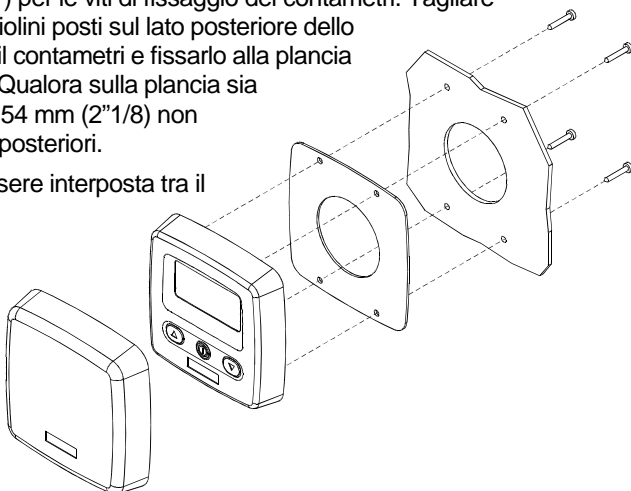

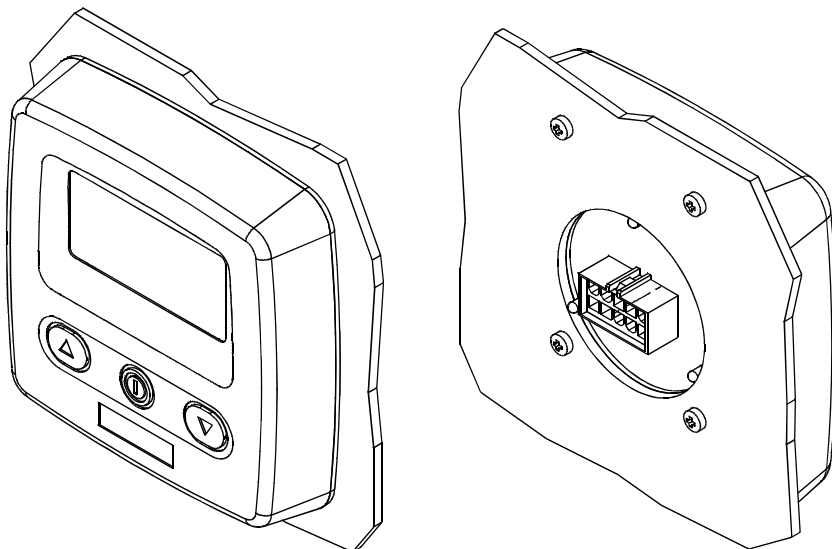

- Per il collegamento elettrico seguire le indicazioni dello schema allegato. I cavi devono avere una sezione minima di 1,5 mm<sup>2</sup>.
- Montare un fusibile di protezione rapido da 4 A (ampere) sul cavo + della batteria. Non utilizzare per l'alimentazione la tensione proveniente dal gruppo batterie motori.
- Lo strumento risponde agli standard EMC (EN55022) e deve essere posizionato a una distanza di:
  - 30 cm (~1 Ft) dalla bussola;
  - 50 cm (~1,5 Ft) da apparecchi radio;
  - 2 metri (~6,5 Ft) da apparecchi radiotrasmettenti;
  - 2 metri (~6,5 Ft) dal fascio radar.

## Collegamenti

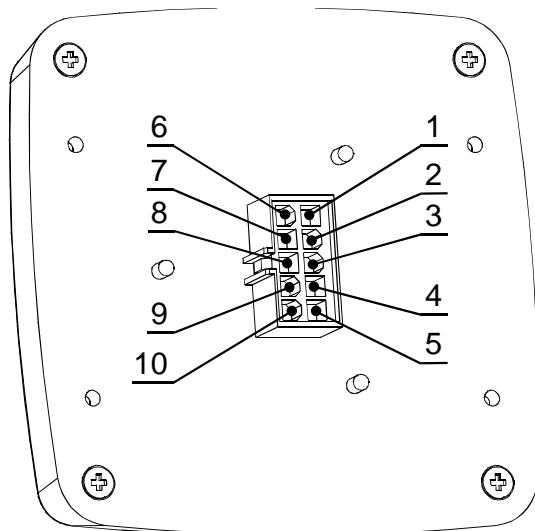



CONNETTORE POSTERIORE A 10 POLI	
PIN	SEGNALE
1	+ Batteria
2	
3	- Batteria
4	
5	
6	Comando UP
7	Comando DOWN
8	
9	Ingresso sensore Cima_Catena
10	Sensore magnetico

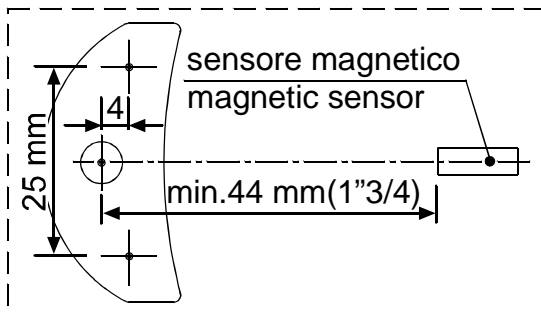
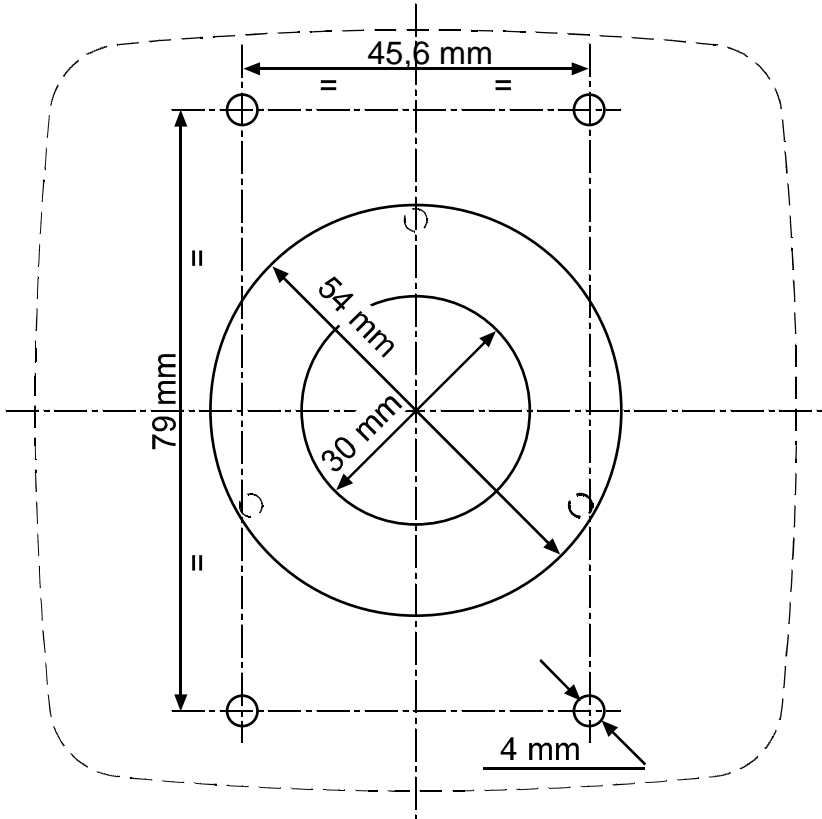

**Foratura contametri e sensore**



## Prima accensione

Il contametri è dotato di un *display* grafico e di tre tasti:  (ON),  (UP) e  (DOWN). Inoltre, è presente un *buzzer* che segnala la pressione sui tasti o attira l'attenzione dell'utilizzatore in particolari condizioni (intervento allarmi).

Il tasto **ON** accende il *display* e abilita gli altri due tasti. Deve essere utilizzato per accedere ai menù di impostazione dei parametri, per selezionare i parametri da modificare e per confermare i valori impostati. Lo spegnimento dell'illuminazione del *display* avviene 30 secondi dopo l'ultimo comando dato (tempo di *default* modificabile – vedi “Tempo BkLight”).

Il tasto **UP** comanda la salita dell'ancora mentre il tasto **DOWN** la cala. Al rilascio di ogni tasto la relativa manovra si interrompe. I due tasti, durante l'impostazione dei parametri, permettono il movimento all'interno del menù e la variazione del valore dei parametri.

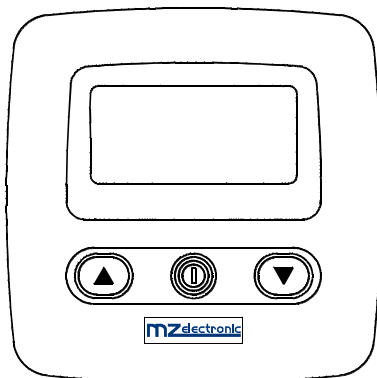

All'accensione lo strumento emetterà un suono e comparirà per alcuni secondi la seguente pagina:



Chain Counter

Completata la procedura di inizializzazione comparirà la pagina principale.



Dove:

**STATO**: indica lo stato dello strumento ed eventuali anomalie.

**VELOCITA'**: indica la velocità della catena, in salita o discesa, in metri al minuto o piedi al minuto.

**CONTEGGIO**: indica la misura della catena calata (in metri o piedi).









**MONITORAGGIO**: indica la tensione di alimentazione.

**ICONE**: è la parte del *display* dove appaiono le icone che indicano la salita o la discesa dell'ancora ed eventuali anomalie.















Alla prima accensione lo strumento si predisporrà come da impostazione all'uscita dalla fabbrica (vedi tabella).

Parametro	Valore di default
Allarme salita	3.0 metri
Discesa automatica	Off
Tempo BackLight	30 secondi
Unità di misura	Metri/centimetri
Misura catena	0.0 metri
Circonferenza Barbotin	33 cm
Tipo sensore	sconosciuto
Beep tasti	Si
Lingua	Italiano
Ore Funzionamento	0
Cima_Catena	Off

















## Menù di impostazione contametri

<p>Mantenendo premuto il tasto  (ON), per sei secondi, si accede al menù di impostazione dello strumento. Sul <i>display</i> comparirà la seguente pagina:</p>	<div style="border: 1px solid black; padding: 5px;"> <p><b>Menu</b></p> <p>Misura</p> <p>Allarmi e Funzioni</p> <p>Impostazioni</p> <p>Lingua</p> <p>Calib. Sensore</p> </div>
<p>Utilizzare il tasto  (DOWN) e  (UP) per spostarsi tra le voci del menù.</p>	<div style="border: 1px solid black; padding: 5px;"> <p><b>Menu</b></p> <p>Lingua</p> <p>Calib. Sensore</p> <p>Verifiche</p> <p>Uscita</p> </div>
<p>Una volta che si è posizionati sulla voce da modificare premere il tasto  (ON) per confermare la scelta.</p>	
<p>Utilizzare i tasti  (DOWN) o  (UP) per spostarsi tra i parametri.</p>	
<p>Una volta che ci si è posizionati sul parametro premere il tasto  (ON) per abilitare la modifica.</p>	
<p>In funzione del tipo di parametro, utilizzando il tasto  (DOWN) e  (UP), è possibile diminuire/aumentare il valore dello stesso o disabilitare/abilitare la funzione.</p>	
<p>Una volta effettuata la modifica premere il tasto  (ON) per confermare.</p>	
<p>Utilizzando il tasto  (DOWN) portarsi sulla voce <b>Uscita</b> e ripremere il tasto  (ON) per ritornare al menù di impostazione. La stessa procedura deve essere utilizzata per ritornare alla pagina principale.</p>	



## Menù Misura





<div style="border: 1px solid black; padding: 5px; width: fit-content; margin: 0 auto;"> <p><b>Misura</b></p> <p>Azzerà Misura      No</p> <p>Unità Misura      Metri</p> <p>Cima_Catena      Off</p> <p>Uscita</p> </div>	
Utilizzare i tasti  ( <b>DOWN</b> ) o  ( <b>UP</b> ) per spostarsi tra i parametri.	
<p><b>Azzerà Misura</b></p> <p>Azzerà il valore della misura della catena (0.0).</p>	<p>Selezionare con </p> <p> = Sì       = No</p> <p>Confermare con </p>
<p><b>Unità Misura</b></p> <p>Si seleziona l'unità di misura:</p> <p style="padding-left: 40px;">Piedi / pollici</p> <p style="padding-left: 40px;">Metri / centimetri</p>	<p>Selezionare con </p> <p> = Piedi       = Metri</p> <p>Confermare con </p>
<p><b>Cima_Catena</b></p> <p>È possibile abilitare la funzione e impostare il valore al quale il sensore passa da cima a catena. Valore impostabile da 0.1 a 25.0 (metri o piedi). Questo valore corrisponde alla lunghezza della catena.</p> <p><b>Per avere questa funzione montare il sensore CMCT-01 (opzionale).</b></p>	<p>Selezionare con </p> <p>Impostare il valore con  </p> <p>Confermare con </p>
<p><b>Uscita</b></p> <p>Per ritornare al menù di impostazione.</p>	<p>Confermare con </p>

## Menù Allarmi e Funzioni







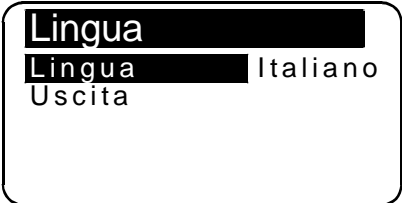

<div style="border: 1px solid black; padding: 5px; width: fit-content; margin: 0 auto;"> <div style="background-color: black; color: white; padding: 2px; display: inline-block;"><b>Allarmi e Funzi</b></div> <table style="width: 100%; border-collapse: collapse;"> <tr> <td style="border-bottom: 1px solid black; padding: 2px;">Alm Salita</td> <td style="padding: 2px;">3.0</td> </tr> <tr> <td style="padding: 2px;">Discesa Aut.</td> <td style="padding: 2px;">Off</td> </tr> <tr> <td style="padding: 2px;">Dati Fabbrica</td> <td style="padding: 2px;">No</td> </tr> <tr> <td style="padding: 2px;">Uscita</td> <td></td> </tr> </table> </div>		Alm Salita	3.0	Discesa Aut.	Off	Dati Fabbrica	No	Uscita	
Alm Salita	3.0								
Discesa Aut.	Off								
Dati Fabbrica	No								
Uscita									
Utilizzare i tasti  ( <b>DOWN</b> ) o  ( <b>UP</b> ) per spostarsi tra i parametri.									
<p><b>Allarme Salita</b>          È possibile abilitare la funzione e stabilire la quota alla quale il salpa ancora si arresta; dopodiché è possibile solo il comando a impulsi.          Valore impostabile: 1.0 - 1.5 - 2.0...5.0 (metri o piedi).</p>	<p>Selezionare con </p> <p>Impostare il valore con  </p> <p>Confermare con </p>								
<p><b>Discesa Automatica</b>          Abilita la procedura di discesa automatica dell'ancora, alla quota desiderata, con la pressione (per almeno 3 sec.) dei tasti  e .</p> <p>Valore impostabile: 5 - 10 - 15...40 (metri o piedi).</p>	<p>Selezionare con </p> <p>Impostare il valore con  </p> <p>Confermare con </p>								
<p><b>Dati Fabbrica</b>          Questa funzione permette di richiamare i dati originali, impostati in fabbrica, <u>cancellando le impostazioni memorizzate</u>.  <b>Usare questo comando solo in caso di una errata programmazione.</b></p>	<p>Selezionare con </p> <p> = Si       = No</p> <p>Confermare con </p>								
<p><b>Uscita</b>          Per ritornare al menù di impostazione.</p>	<p>Confermare con </p>								

## Menù Impostazioni

<div style="border: 1px solid black; padding: 5px; width: fit-content; margin: 0 auto;"> <p><b>Impostazioni</b></p> <p><b>Contrasto</b></p> <p>Luce LCD</p> <p>Tempo BkLight      30</p> <p>Beep Tasti          Si</p> <p>Uscita</p> </div>	
Utilizzare i tasti  ( <b>DOWN</b> ) o  ( <b>UP</b> ) per spostarsi tra i parametri.	
<p><b>Contrasto</b></p> <p>Abilitando questa funzione è possibile avviare la procedura di programmazione del contrasto del <i>display</i>.</p>	<p>Selezionare con </p> <p>Impostare il valore con  </p> <p>Confermare con </p>
<p><b>Luce LCD</b></p> <p>Abilitando questa funzione è possibile avviare la procedura di programmazione dell'intensità della luce del <i>display</i>.</p>	<p>Selezionare con </p> <p>Impostare il valore con  </p> <p>Confermare con </p>
<p><b>Tempo BackLight</b></p> <p>Questa funzione permette di impostare il tempo di accensione della luce durante il quale il <i>display</i> rimane acceso dopo l'ultimo comando dato (valore di default 30 secondi).</p>	<p>Selezionare con </p> <p>Impostare il valore con  </p> <p>Confermare con </p>

<p><b>Beep Tasti</b> Questa funzione permette di abilitare o disabilitare il <i>buzzer</i> (suono emesso ad ogni pressione dei tasti).</p>	<p>Selezionare con </p> <p> = No       = Si</p> <p>Confermare con </p>
<p><b>Uscita</b> Per ritornare al menù di impostazione.</p>	<p>Confermare con </p>

## Menù Lingua





	
<p>Utilizzare i tasti  (<b>DOWN</b>) o  (<b>UP</b>) per spostarsi tra i parametri.</p>	
<p><b>Lingua</b> È possibile selezionare la lingua del <i>display</i>:</p> <ul style="list-style-type: none"> <li>Italiano</li> <li>English</li> <li>Français</li> <li>Deutsch</li> <li>Español</li> </ul>	<p>Selezionare con </p> <p>Impostare il valore con  </p> <p>Confermare con </p>
<p><b>Uscita</b> Per ritornare al menù di impostazione.</p>	<p>Confermare con </p>



## Menù Calibrazione Sensore

<div style="border: 1px solid black; padding: 5px; width: fit-content; margin: auto;"> <p><b>Calib. Sensore</b></p> <p><b>Rilev. Sens.</b></p> <p>C. Barbotin                      33.0</p> <p>Uscita</p> </div>	
Utilizzare i tasti  ( <b>DOWN</b> ) o  ( <b>UP</b> ) per spostarsi tra i parametri.	
<p><b>Rilevamento Sensore</b></p> <p>Questa funzione ha lo scopo di calibrare lo strumento in funzione del tipo di sensore montato (Standard o Project).</p> <p>La seconda schermata indica il tempo per un periodo del sensore e il tipo dello stesso.</p>	<p style="text-align: center;">Selezionare con </p> <div style="border: 1px solid black; padding: 5px; width: fit-content; margin: auto;"> <p><b>Rilev. Sens.</b></p> <p>Premi Salita/Discesa per azionare motore</p> </div>
Premere  o 	
<div style="border: 1px solid black; padding: 5px; width: fit-content; margin: auto;"> <p><b>Rilev. Sens.</b></p> <p>Premi Salita/Discesa per azionare motore 0.400 sec.</p> <p>Sensore Std.</p> </div>	<div style="border: 1px solid black; padding: 5px; width: fit-content; margin: auto;"> <p><b>Rilev. Sens.</b></p> <p>Premi Salita/Discesa per azionare motore 0.400 sec.</p> <p>Sensore Proj.</p> </div>
Confermare con 	

Una volta che la routine di “Rilevamento Sensore” abbia individuato un sensore di tipo “Standard” piuttosto che “Project” al successivo ingresso nel menù “Calib.Sensore” le voci dello stesso cambiano in funzione del sensore trovato.

<p align="center"><b>Menù sensore Standard e Project serie X..</b> (sensore e magnete applicati nel <u>barbotin</u>)</p> <div style="border: 1px solid black; padding: 5px; margin: 10px 0;"> <p align="center"><b>Calib. Sensore</b></p> <p>C. Barbotin      33.0</p> <p>Uscita</p> </div>	<p align="center"><b>Menù sensore Project serie 1000 – 1500 – 2000 W</b> (sensore e magnete applicati nel <u>motore</u>)</p> <div style="border: 1px solid black; padding: 5px; margin: 10px 0;"> <p align="center"><b>Calib. Sensore</b></p> <p>Fattore Rid.      57.0</p> <p>Uscita</p> </div>
<p><b>Circonferenza Barbotin</b> In questa riga si deve inserire la circonferenza del Barbotin (in centimetri o pollici). Per calcolare la circonferenza utilizzare la <b>Tabella 1</b>. Valore impostabile: centimetri o pollici. Impostato di default sul valore di 33 cm.</p>	<p><b>Fattore Riduzione</b> In questa riga si deve inserire il fattore di riduzione. Per scegliere il corretto valore da inserire riferirsi alla <b>Tabella 2</b>. Impostato di default sul valore di 57.</p>
<p>Selezionare con </p> <p>Impostare il valore con  </p> <p>Confermare con </p>	
<p><b>Uscita</b> Per ritornare al menù di impostazione.</p>	<p>Confermare con </p>

**Tabella 1 - Sensore Standard e Project serie X..**  
(sensore e magnete applicati nel barbotin)

Misura catena	Numero di rientranze	Circonferenza Barbotin (cm)	Circonferenza Barbotin (pollici)
6 mm	9	34	13
7 mm	6	25	9
8 mm	6	28	11
	7	33*	13
	8	38	15
10 mm	5	31	12
	6	36	14
12 mm	5	36	14
	6	43	17
13 mm	6	46	18
14 mm	5	42	16
3/8" BBB	7	38	15
3/8" HT	6	37	14
5/16" HT	7	36	14
1/2" BBB	6	40	16
1/2" HT	5	40	16





\* impostazione dello strumento all'uscita dalla fabbrica



**Tabella 2 - Sensore Project serie 1000 – 1500 – 2000W**  
(sensore e magnete applicati nel motore)

Modello	Circonferenza Barbotin (cm)	Rapporto riduzione	Numero di rientranze	Misura catena (mm-pollici)	Fattore Riduzione
Project 1000	30	1:52	6	8-5/16"HT	57*
	30	1:52	5	10 DIN 766	
	31	1:52	5	10 ISO-3/8"HT	59
	34	1:52	9	6	65
Project 1500	30	1:70	6	8-5/16"HT	43
	30	1:70	5	10 DIN 766	43
	31	1:70	5	10 ISO-3/8"HT	44
	36	1:70	5	12 ISO-13 DIN 766-7/16"HT	51
Project 2000	39	1:75	6	3/8"HT	52
	40	1:75	6	3/8"Proof Coil	53
	41	1:75	6	10 DIN 766-3/8"BBB	54
	44	1:75	7	10 ISO	58
	45	1:75	5	14 ISO	60
	46	1:75	6	12 ISO-13 DIN 766	61
	47	1:75	5	13 DIN 764	63

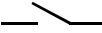
\* impostazione dello strumento all'uscita dalla fabbrica

## Menù Verifiche

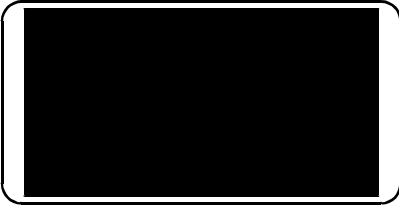
<div style="border: 1px solid black; padding: 5px;"><b>Verifiche</b> <b>Test Sensore</b> Test LCD. Versione Sw.      1.01 Ore Funz.            0 Uscita</div>	
Utilizzare i tasti  (DOWN) o  (UP) per spostarsi tra i parametri.	
<b>Test Sensore</b> Questa funzione ha lo scopo di verificare lo stato del sensore:  contatto aperto           contatto chiuso	<p>Selezionare con </p> <div style="border: 1px solid black; padding: 5px; margin-bottom: 10px;"><b>Stato Sensore</b> </div> <div style="border: 1px solid black; padding: 5px;"><b>Stato Sensore</b> </div> <p>Confermare con </p>

<b>Test LCD.</b> Questa funzione accende tutti i <i>pixel</i> del <i>display</i> permettendone la verifica.	Selezionare con   Confermare con 
<b>Versione Sw.</b> Indica la versione del <i>software</i> .	
<b>Ore Funz.</b> Indica le ore di funzionamento del verricello.	
<b>Uscita</b> Per ritornare al menù di impostazione.	Confermare con 

## Calibrazione dello strumento

Prima di utilizzare lo strumento è necessario procedere all'impostazione dei seguenti parametri:

- scelta dell'Unità di Misura (metri o piedi);
- impostazione della funzione Cima\_Catena (**sensore opzionale tipo CMCT-01**);

<b>Misura</b>	
Azzerà Misura	No
Unità' Misura	Metri
<b>Cima_Catena</b>	Off
Uscita	

- rilevamento del tipo di Sensore (Standard o Project);
- impostazione del diametro del barbotin (valore di default 33 cm) o del fattore riduzione (valore di default 57);

### Menù sensore Standard e Project serie X..

<b>Calib. Sensore</b>	
<b>C. Barbotin</b>	33.0
Uscita	

### Menù sensore Project serie 1000 – 1500 – 2000 W

<b>Calib. Sensore</b>	
<b>Fattore Rid.</b>	57.0
Uscita	

## Utilizzo

Premere il tasto  (**ON**) per attivare i comandi e illuminare il *display*. Lo spegnimento dell'illuminazione del *display* avviene 30 secondi dopo l'ultimo comando dato (tempo di *default* modificabile – vedi “Tempo BkLight”).

Premendo il tasto  (**UP**) si comanda la salita dell'ancora.

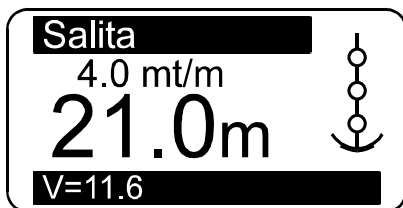



Premendo il tasto  (**DOWN**) si cala l'ancora.



Al rilascio di ogni tasto di comando (**UP** o **DOWN**) la relativa manovra si interrompe.

## Reset della misura

Per azzerare il conteggio della misura premere il tasto  (ON) e contemporaneamente il tasto  (UP) per almeno tre secondi.



L'azzeramento della misura si può anche effettuare nel menù **Misura** selezionando “Si” nella riga **Azzer Misura**.

Misura	
Azzer Misura	No
Unita' Misura	Metri
Cima_Catena	Off
Uscita	

## Discesa automatica dell'ancora

Questa funzione deve essere abilitata nel menù **Allarmi e Funzioni** (di *default* la funzione è disabilitata).

Allarmi e Funzi	
Alm Salita	3.0
Discesa Aut.	Off
Dati Fabbrica	No
Uscita	

Selezionare la voce “**Discesa Aut.**” ed impostare il valore al quale si desidera arrestare l'ancora. Dopo che è stata impostata la quota premere il tasto  (ON) e contemporaneamente il tasto  (DOWN) per almeno tre secondi. Una volta avviata la discesa dell'ancora rilasciare i tasti.

**È comunque possibile, per ragioni di sicurezza, interrompere la discesa automatica premendo un tasto qualsiasi dello strumento.**

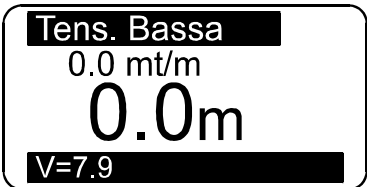

## Anomalie di funzionamento

SEGNALAZIONE	CAUSA	RIMEDIO
	<p>Mentre si manteneva premuto il tasto <b>UP</b> o <b>DOWN</b> lo strumento non ha ricevuto nessun segnale dal sensore magnetico per più di 5 secondi.</p>	<p>Verificare i collegamenti elettrici del sensore.</p> <p>Verificare il funzionamento del sensore e se guasto provvedere alla sostituzione.</p> <p>Verificare la posizione del sensore, del magnete sul barbotin e la distanza tra i due (3 mm).</p> <p>Verificare il funzionamento dell'impianto elettrico o del salpa ancora stesso</p>
	<p>La tensione di alimentazione dello strumento è inferiore ai 10V.</p>	<p>Verificare lo stato di carica della batteria o il funzionamento dell'impianto elettrico.</p>

## Garanzia

I nostri articoli sono garantiti contro eventuali difetti di fabbricazione per 2 anni a partire dalla data di acquisto (farà fede lo scontrino fiscale o altra prova d'acquisto). Non sono comprese nella garanzia: avarie e rotture causate dal trasporto, interventi effettuati per problemi causati da erronea installazione, avarie causate da uso improprio dell'apparecchio. La garanzia decade nell'ipotesi di manutenzione o riparazioni effettuate da persone non autorizzate dall'azienda o eseguite con l'applicazione di pezzi di ricambio non originali. La garanzia non prevede in nessun caso l'integrale sostituzione dell'apparecchio. La garanzia si riferisce esclusivamente alla sostituzione dei pezzi difettosi ed alla relativa manodopera. Non comprende il trasporto o le spese di trasferta. Il Cliente non potrà pretendere alcun rimborso per le spese sostenute.

## Description

The **EV-030** chain counter displays the length of chain let out or down, expressed in metres or feet and the speed of the same.

## Technical data

Power supply	from 10 to 30 V DC
Current intake	min. 5 mA – max 40 mA
Protection rating of front cover	IP65*
Operative temperature	0 / +70 °C (32 / 158 °F)
Graphic display	128 x 64 pixels
Max. chain length	999 metres – 999 feet
Size (mm)	100 x 100 x 32**
Weight (g)	160

\* excluding cable connection zone - \*\* without protective cover



### **Warning**

**CONNECT ONLY TO A DC POWER SUPPLY.**

## General notes

The **EV-030** chain counter must be used solely for the purposes described herein, i.e. to operate and display the number of metres/feet of chain let out by an anchor windlass. Any other use is to be considered improper.

**Any tampering with the instrument will result in immediate voiding of the warranty.**

## Components

### The package contains:

- chain counter, seal and closure cover;
- 10-pole male connector with crimp-type 10 male contacts;
- magnetic sensor;
- support kit (support for the vertical shaft anchor windlass sensor, supporting base, 2 fastening screws, O-ring);
- magnet;
- horizontal shaft anchor windlass sensor support;
- instructions for use.

## Installation

**On a few models of anchor windlass the sensor and the magnet are already installed (chain counter setting). Therefore, the operations described below are not necessary.**

### Installing the magnet on the anchor windlass

- A hole having a diameter of 6.5 mm (~1/4") and depth of 8 mm (5/16") must be drilled on a tooth of the gipsy, in a place outside the chain's path.
- In the case of vertical shaft anchor windlasses (see Fig. 1B), drill the hole in the lower circumference of the gipsy.
- In the case of horizontal shaft anchor windlasses (see Fig. 2B), drill the hole in the outer circumference of the gipsy.
- Also make sure that the protruding part of the magnet will not collide with the base or sensor during rotation of the gipsy.
- Insert the metal part of the magnet in the hole, allowing the protected part to protrude by about 2 mm. Fix it in place using an adhesive for metals (two-component epoxy glue) or silicone. The glue used must be able to withstand a marine environment.

## Installing the magnetic sensor for vertical shaft anchor windlasses

(see Fig. 1A – 1B)

- Drill a 4 mm (~3/16") hole in the cover through which to thread the sensor cable.
- Fasten Part A of the support with the two screws provided, after having positioned the O-ring in the lower part of the support.
- Fit Part B with the magnetic sensor on support A and adjust its height until it is aligned with the magnet fastened on the gipsy.
- Bring the sensor to a distance of about 3 mm (~1/8") from the magnet and secure it in place by tightening screw G1. Then tighten screw G2.

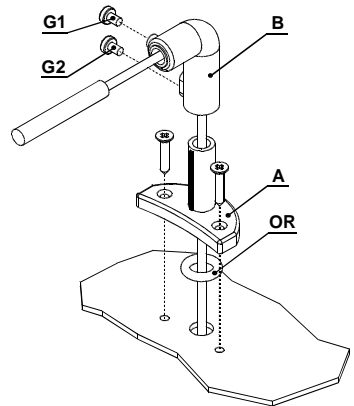

## Installing the magnetic sensor for horizontal shaft anchor windlasses

(see Fig. 2A – 2B – 2C)

- Drill a 4 mm (~3/16") hole in the cover through which to thread the sensor cable.
- Fasten Part A of the support with the two screws provided, after having positioned the O-ring in the lower part of the support.
- Cut Part C to measure using a hacksaw. The sensor must be positioned at a distance of about 3 mm (~1/8") from the magnet.
- Fit Part C with the magnetic sensor on support A and fix it in place using an adhesive for plastic (two-component epoxy glue) or silicone.
- Using the same glue, attach the sensor to Part C.

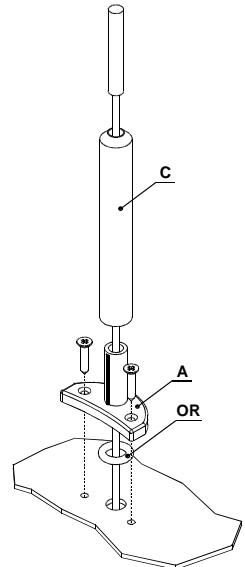

## Installing the chain counter

(see connection diagram)



### Warning

**ALWAYS DISCONNECT THE BATTERY PRIOR TO INSTALLATION.**

- The chain counter must be positioned so that the display will be easy to read. It should not be exposed to direct sunlight.
- The rear part of the instrument must be protected from contact with water or moisture.
- The instrument may be fastened to dashboards of any thickness. The screws used for clamping must be of the self-threaded kind and with a diameter of 3.5 mm (~9/64") and a maximum length of 10 mm plus the thickness of the dashboard.
- In the part to the rear of the dashboard there must be minimum clearance of 35 mm (1" 3/8) and there must also be adequate access to perform installation and maintenance work.
- On the dashboard make a hole with a diameter of 30 mm (~ 1" 3/16), as indicated, and 4 holes with diameters of 4 mm (~5/32") for the chain counter clamping screws. Use cutting nippers to cut the three pins on the back of the instrument, position the chain counter and fasten it to the dashboard by tightening the four screws. If the dashboard already has a hole with a 54 mm (2"1/8) diameter, it is not necessary to cut the pins on the back.
- The seal must be positioned between the chain counter and the dashboard.

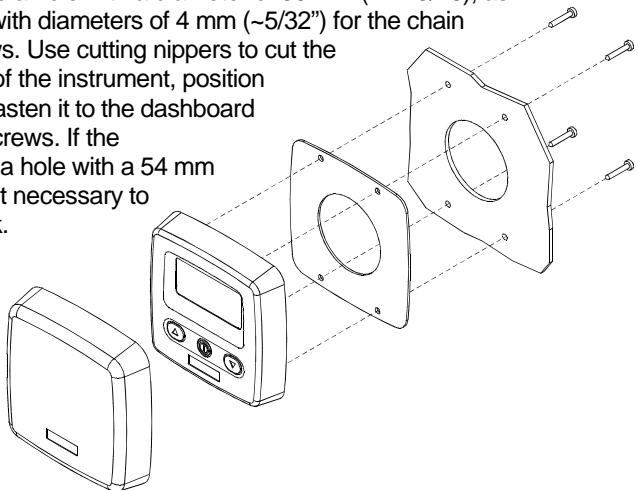

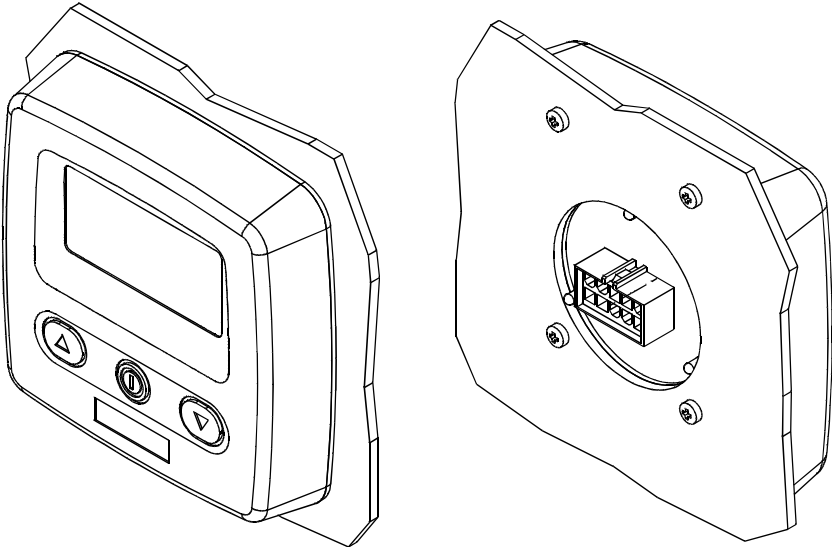

- For instructions on making electrical connections, see the attached diagram. The wires must have a minimum cross section size of 1.5 mm<sup>2</sup>.
- Install a 4 A (ampere) fast safety fuse on the + wire of the battery. Do not use the voltage generated by the engine battery set to provide power.
- The instrument complies with EMC standards (EN55022) and must be positioned at a distance of:
  - 30 cm (~1 Ft) from the compass;
  - 50 cm (~1.5 Ft) from radio equipment;
  - 2 metres (~6.5 Ft) from radio transmitter equipment;
  - 2 metres (~6.5 Ft) from the radar beam.

## Connections

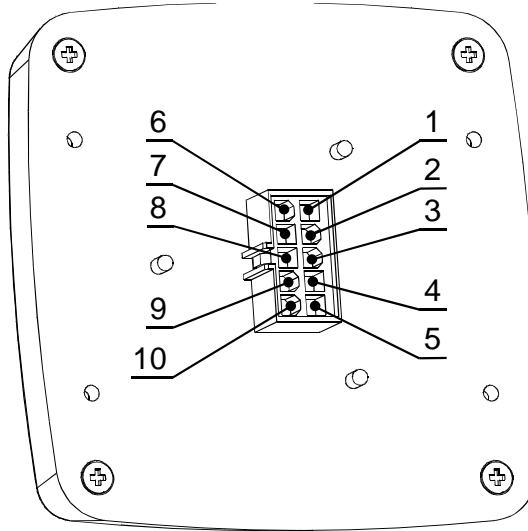

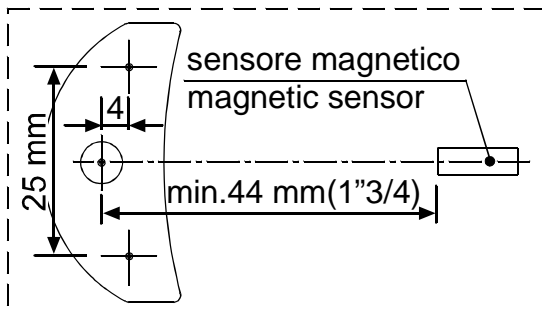
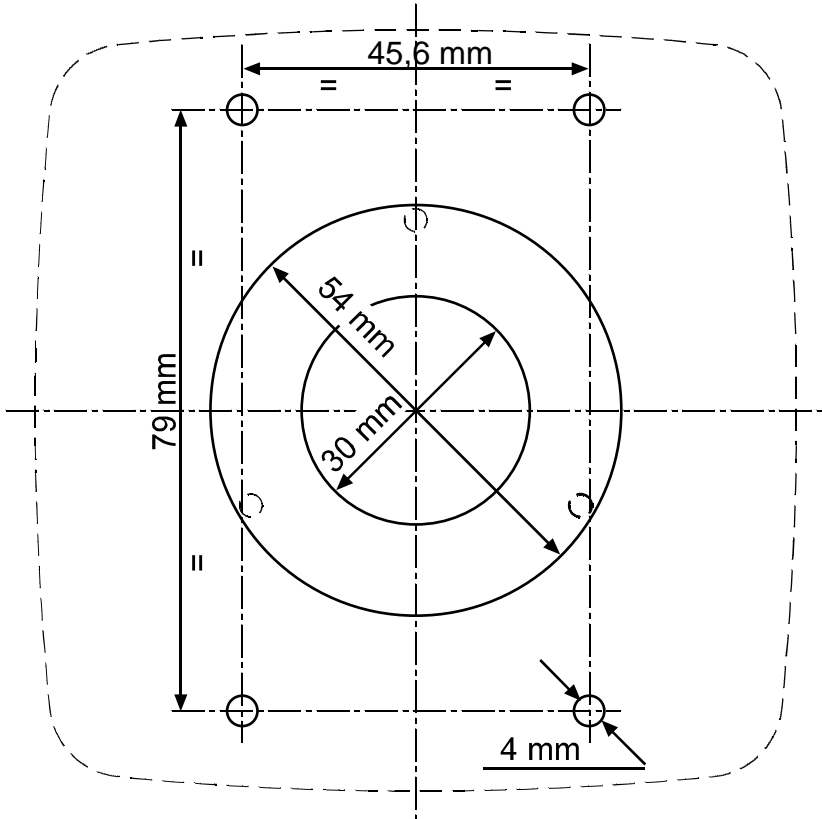

10-POLE REAR CONNECTOR	
PIN	SIGNAL
1	+ Battery
2	
3	- Battery
4	
5	
6	UP command
7	DOWN command
8	
9	Rope_Chain sensor input
10	Magnetic sensor

**Chain counter and sensor hole**





## Starting up

The chain counter features a graphic display and three keys:  (**ON**),  (**UP**) and  (**DOWN**). There is also a buzzer that indicates the pressing of the keys or attracts the user's attention in particular conditions (alarm triggering).

The **ON** key switches on the display and enables the other two keys. It must be used to access the parameter setting menus. For selecting the parameters to be modified and to confirm the values set. The display backlight will switch off 30 seconds after the last command given (adjustable default time – see “BkLight Time”).

The **UP** key commands the hoisting of the anchor and the **DOWN** key casts it. When the key is released, the action is stopped. During parameter setting, the two keys allow the User to move around the menu and vary parameter values.

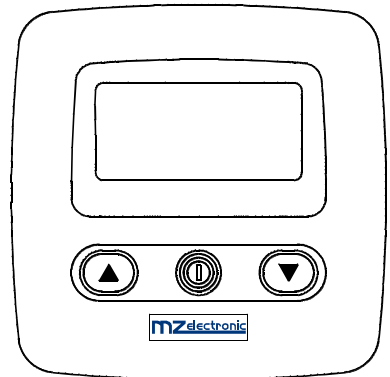

When switched on, the instrument will make a beep and the following page will appear for a few seconds:



Once the initialisation procedure is complete, the main page will appear.

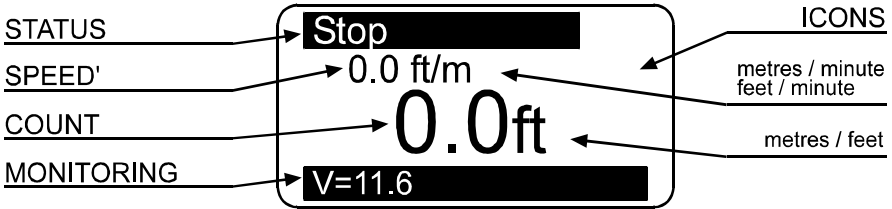

Where:

**STATUS:** indicates the status of the instrument and any failure.

**SPEED':** indicates the chain speed during hoisting or lowering in meters per minute or feet per minute.

**COUNT:** indicates the measurement of the chain lowered (in metres or feet).













**MONITORING:** indicates the power supply voltage.

**ICONS:** this is the part of the *display* bearing the icons that indicate the hoisting or casting of the anchor and any failure.











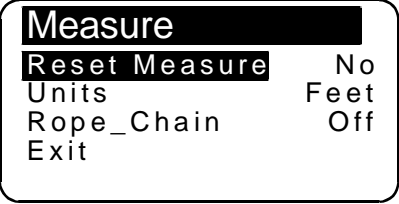





When the instrument is turned on for the first time, it will set up as programmed in the factory (see table).

Parameter	Default value
Up Alarm	3.0 metres
Auto Down	Off
BackLight Time	30 seconds
Units of measurement	Metres/centimetres
Chain Measure	0.0 metres
Barbotin Circumference	33 cm
Sensor type	unknown
Keyboard Beep	Yes
Language	Italian
Works Hours	0
Rope_Chain	Off

















## Chain counter setting menu

<p>Hold down the  (ON) key for six seconds to access the instrument setting menu. The following page will appear on the display:</p>	<p><b>Menu</b>  <b>Measure</b>          Alarms &amp; Function          Settings          Language          Sensor Calibration</p>
<p>Use the  (DOWN) and  (UP) keys to move around the menu options.</p>	<p><b>Menu</b>          Language  <b>Sensor Calibration</b>          Tests          Exit</p>
<p>Once you are positioned on the item to be modified press the  (ON) key to confirm your choice.</p>	
<p>Use the  (DOWN) or  (UP) keys to move from one parameter to another.</p>	
<p>Once one is positioned on the parameter press the  (ON) key to enable modification.</p>	
<p>According to the type of parameter, using the  (DOWN) and  (UP) keys it is possible to reduce/increase the value of the same or disable/enable the function.</p>	
<p>Once the modification has been performed, press the  (ON) key to confirm.</p>	
<p>Using the  (DOWN) key go to the <b>Exit</b> option and press the  (ON) key again to return to the setting menu. The same procedure must be used to return to the main page.</p>	











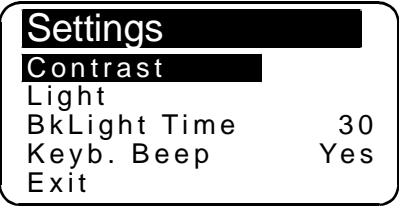



**Measurement menu**





	
<p>Use the  (DOWN) or  (UP) key to move around the parameters.</p>	
<p><b>Reset Measurement</b> Resets the chain measurement value (0.0).</p>	<p>Select with </p> <p> = Yes       = No</p> <p>Confirm with </p>
<p><b>Units</b> Selects the unit of measurement:</p> <p style="padding-left: 40px;">Feet/ inches Metres / centimetres</p>	<p>Select with </p> <p> = Feet       = Metres</p> <p>Confirm with </p>
<p><b>Rope_Chain</b> It is possible to enable the function and set the value at which the sensor passes from rope to chain. Setting range 0.1 - 25.0 (metres or feet). This value corresponds to the chain length. <b>To obtain this function, install sensor CMCT-01 (optional).</b></p>	<p>Select with </p> <p>Set value with  </p> <p>Confirm with </p>
<p><b>Exit</b> To return to the settings menu.</p>	<p>Confirm with </p>

**Alarm and functions menu**







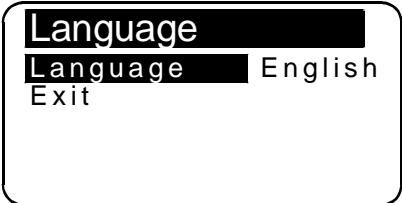

<div style="border: 1px solid black; padding: 5px; width: fit-content; margin: 0 auto;"> <p><b>Alarms &amp; Functi</b></p> <p><b>Up Alarm</b> 3.0</p> <p>Auto Down Off</p> <p>Load Default No</p> <p>Exit</p> </div>	
<p>Use the  (DOWN) or  (UP) key to move around the parameters.</p>	
<p><b>Up Alarm</b></p> <p>It is possible to enable the function and establish the height at which the anchor-winch stops; after which it is only possible to give pulsed commands.</p> <p>Settable values: 1.0 - 1.5 - 2.0...5.0 (metres or feet).</p>	<p>Select with </p> <p>Select value with  </p> <p>Confirm with </p>
<p><b>Auto Down</b></p> <p>Enables the automatic anchor lowering procedure, at the desired height, with the pressing (for at least 3 seconds) of the keys  and .</p> <p>Settable value: 5 - 10 - 15...40 (metres or feet).</p>	<p>Select with </p> <p>Select value with  </p> <p>Confirm with </p>
<p><b>Load Default</b></p> <p>This function allows the User to revert to the original factory default settings, <u>thus erasing all settings memorised.</u> <b>This command must only be used in the event of programming errors.</b></p>	<p>Select with </p> <p> = Yes       = No</p> <p>Confirm with </p>
<p><b>Exit</b></p> <p>To return to the settings menu.</p>	<p>Confirm with </p>

**Settings menu**







	
Use the  (DOWN) or  (UP) key to move around the parameters.	
<p><b>Contrast</b> By enabling this function it is possible to start the display contrast programming procedure.</p>	<p>Select with </p> <p>Select value with  </p> <p>Confirm with </p>
<p><b>Light</b> By enabling this function it is possible to start the display luminous intensity programming procedure.</p>	<p>Select with </p> <p>Select value with  </p> <p>Confirm with </p>
<p><b>BackLight Time</b> This function allows the user to set the backlight on time during which the display remains lit after the last command given (default value 30 seconds).</p>	<p>Select with </p> <p>Select value with  </p> <p>Confirm with </p>

<p><b>Keyboard Beep</b> This function allows the user to enable or disable the buzzer (emitted each time a key is pressed).</p>	<p>Select with </p> <p> = No       = Yes</p> <p>Confirm with </p>
<p><b>Exit</b> To return to the settings menu.</p>	<p>Confirm with </p>





## Language menu

	
<p>Use the  (<b>DOWN</b>) or  (<b>UP</b>) key to move around the parameters.</p>	
<p><b>Language</b> The user may select the display language:</p> <ul style="list-style-type: none"> <li>Italian</li> <li>English</li> <li>French</li> <li>German</li> <li>Spanish</li> </ul>	<p>Select with </p> <p>Select value with  </p> <p>Confirm with </p>
<p><b>Exit</b> To return to the settings menu.</p>	<p>Confirm with </p>

**Sensor calibration menu**

<div style="border: 1px solid black; border-radius: 15px; padding: 10px; width: fit-content; margin: 0 auto;"> <p><b>Sensor Calibrat</b></p> <p><b>Sensor Detect</b></p> <p>Barb. Circ.                      33.0</p> <p>Exit</p> </div>	
<p>Use the  (DOWN) or  (UP) key to move around the parameters.</p>	
<p><b>Sensor Detect</b></p> <p>This function has the purpose of calibrating the instrument according to the type of sensor installed (Standard or Project).</p> <p>The second screen indicates the time for a sensor period and type.</p>	<p>Select with </p> <div style="border: 1px solid black; border-radius: 15px; padding: 10px; width: fit-content; margin: 10px auto;"> <p><b>Sensor Detect.</b></p> <p>Press Up/Down Key to run the motor</p> </div>
<p>Press  or </p>	
<div style="border: 1px solid black; border-radius: 15px; padding: 10px; width: fit-content; margin: 0 auto;"> <p><b>Sensor Detect</b></p> <p>Press Up/Down Key to run the motor</p> <p>0.400 sec.</p> <p>Sensor:Std</p> </div>	<div style="border: 1px solid black; border-radius: 15px; padding: 10px; width: fit-content; margin: 0 auto;"> <p><b>Sensor Detect</b></p> <p>Press Up/Down Key to run the motor</p> <p>0.400 sec.</p> <p>Sensor:Proj.</p> </div>
<p>Confirm with </p>	



<p>Once the “Sensor Detection” function has recognised a “Standard” type sensor instead of a “Project” sensor, when the “Sensor Calibrat.” menu is entered again, the menu options will “configure” themselves according to the sensor detected.</p>	
<p><b>Standard and X.. Project series sensor menu</b> (magnet and sensor placed <u>on barbotin</u>)</p> <div style="border: 1px solid black; padding: 5px; margin: 5px 0;"> <p><b>Sensor Calibrat</b></p> <p>Barb. Circ.      33.0</p> <p>Exit</p> </div>	<p><b>1000 – 1500 –2000 W Project series sensor menu</b> (magnet and sensor placed <u>on motor</u>)</p> <div style="border: 1px solid black; padding: 5px; margin: 5px 0;"> <p><b>Sensor Calibrat</b></p> <p>Red. Factor      57.0</p> <p>Exit</p> </div>
<p><b>Barbotin Circumference</b> In this row the user must enter the circumference of the gipsy (in centimetres or inches). Use the <b>Table 1</b> provided to calculate the circumference. Settable values: centimetres or inches. Default value, 33 cm.</p>	<p><b>Reduction Factor</b> In this row the user must enter the reduction factor. See next <b>Table 2</b> for the correct value to be entered Default value, 57.</p>
<p>Select with </p> <p>Select value with  </p> <p>Confirm with </p>	
<p><b>Exit</b> To return to the settings menu.</p>	<p>Confirm with </p>

**Table 1 - Standard and Project X.. series sensor  
(magnet and sensor placed on barbotin)**

Chain type	Number of recesses	Gipsy Circumference (cm)	Gipsy Circumference (inches)
6 mm	9	34	13
7 mm	6	25	9
8 mm	6	28	11
	7	33*	13
	8	38	15
10 mm	5	31	12
	6	36	14
12 mm	5	36	14
	6	43	17
13 mm	6	46	18
14 mm	5	42	16
3/8" BBB	7	38	15
3/8" HT	6	37	14
5/16" HT	7	36	14
1/2" BBB	6	40	16
1/2" HT	5	40	16





\* factory setting of instrument



**Table 2 - 1000 – 1500 – 2000W Project series sensor  
(magnet and sensor placed on motor)**

Type	Gipsy Circumf. (cm)	Reduction ratio	Number of recesses	Chain type (mm-inches)	Reduction Factor
Project 1000	30	1:52	6	8-5/16"HT	57*
	30	1:52	5	10 DIN 766	
	31	1:52	5	10 ISO-3/8"HT	59
	34	1:52	9	6	65
Project 1500	30	1:70	6	8-5/16"HT	43
	30	1:70	5	10 DIN 766	43
	31	1:70	5	10 ISO-3/8"HT	44
	36	1:70	5	12 ISO-13 DIN 766-7/16"HT	51
Project 2000	39	1:75	6	3/8"HT	52
	40	1:75	6	3/8"Proof Coil	53
	41	1:75	6	10 DIN 766-3/8"BBB	54
	44	1:75	7	10 ISO	58
	45	1:75	5	14 ISO	60
	46	1:75	6	12 ISO-13 DIN 766	61
	47	1:75	5	13 DIN 764	63

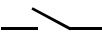
\* factory setting of instrument

**Check menu**

<div style="border: 1px solid black; padding: 5px; width: fit-content; margin: 0 auto;"> <p><b>Tests</b></p> <p><b>Sens. Checks</b></p> <p>LCD Test</p> <p>Sw. Version            1.01</p> <p>Work Hours            0</p> <p>Exit</p> </div>	
<p>Use the  (DOWN) or  (UP) key to move around the parameters.</p>	
<p><b>Sensor Checks</b></p> <p>The purpose of this function is to check the state of the sensor:</p> <p style="text-align: center; margin-top: 20px;">contact open</p>    <p style="text-align: center;">contact closed</p>	<p style="text-align: center;">Select with </p> <div style="border: 1px solid black; padding: 10px; margin: 10px auto; width: 80%;"> <p><b>Sensor Test</b></p> <div style="text-align: center; margin-top: 20px;">  </div> </div> <div style="border: 1px solid black; padding: 10px; margin: 10px auto; width: 80%;"> <p><b>Sensor Test</b></p> <div style="text-align: center; margin-top: 20px;">  </div> </div> <p style="text-align: center;">Confirm with </p>

<p><b>LCD Test</b>          This function switches on all the display's pixels thus making it possible to perform a check on them.</p>	<p>Select with </p> <div style="border: 1px solid black; width: 150px; height: 100px; margin: 10px auto; background-color: black;"></div> <p>Confirm with </p>
<p><b>Software Version</b>          Indicates the version of the software installed.</p>	
<p><b>Work Hours</b>          Indicates the hours of operation of the winch.</p>	
<p><b>Exit</b>          To return to the settings menu.</p>	<p>Confirm with </p>

## Instrument calibration

Before using the instrument the following parameters must be set:

- choice of unit of measurement (metres or feet);
- Setting of the Rope\_Chain function (**optional sensor type CMCT-01**);

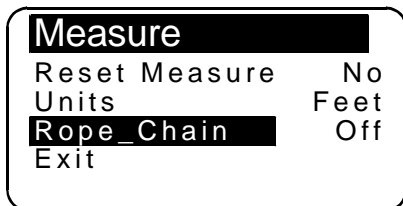

- detection of type of sensor (Standard or Project);
- gipsy diameter setting (default value 33 cm) or reduction factor (default value 57);

**Standard and X.. Project series  
sensor menu**

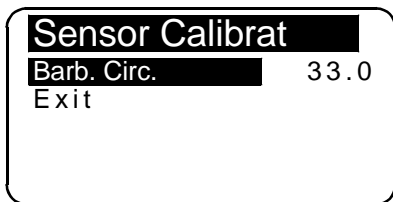

**1000 – 1500 –2000 W Project series  
sensor menu**

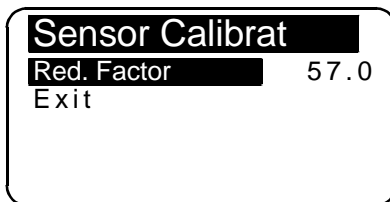

## Use

Press the  (**ON**) key to activate controls and to switch on the display lighting. The *display* lighting switches off 30 seconds after the last command given (adjustable *default* time – see “BkLight Time”).

Press key  (**UP**) to control the anchor ascending.

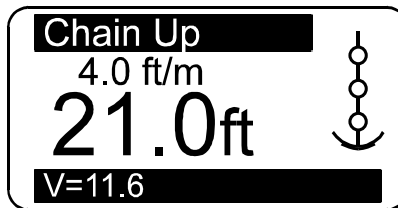

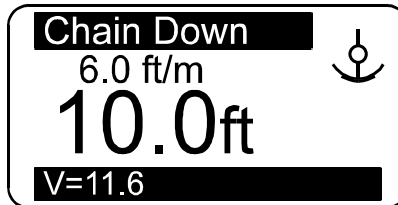

Press key  (**DOWN**) to cast anchor.



When any key is released (**UP or DOWN**) the corresponding action is stopped.

## Measurement reset

To reset the measurement count simultaneously press the  (ON) and the  (UP) keys for at least three seconds.

Measurement reset may also be performed in the **Measurement** menu by selecting “Yes” in the **Reset Measure** row.

Measure	
Reset Measure	No
Units	Feet
Rope_Chain	Off
Exit	

## Automatic casting of the anchor

This function must be enabled in the **Alarms and Functions** menu (disabled by default).

Alarms & Functi	
Up Alarm	3.0
Auto Down	Off
Load Default	No
Exit	

Select the row “Auto Down” and set the value at which the anchor must stop.

Then press the  (ON) and  (DOWN) keys for at least three seconds. Once anchor casting has commenced, release the keys.

**For safety reasons it is however possible to interrupt automatic descent by pressing any instrument key.**

## Troubleshooting

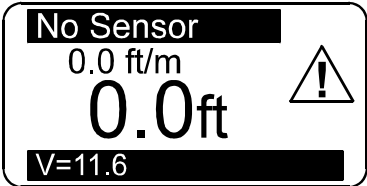
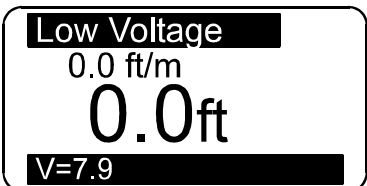
FAULT	CAUSE	CORRECTIVE ACTION
	<p>Though <b>UP</b> or <b>DOWN</b> keys are pressed, the instrument doesn't receive any signal from the magnetic sensor for more than 5 seconds.</p>	<p>Check the sensor electric connections.</p> <p>Check if sensor operates properly. If not, replace it.</p> <p>Check the position of sensor and magnet on gipsy and their distance (3 mm).</p> <p>Check the operation of electric installation or anchor windlass.</p>
	<p>The instrument's power supply voltage is lower than 10V.</p>	<p>Verify the battery charge or operation of the electrics system.</p>

## Warranty

We guarantee our products from manufacturing defects for 2 years from the purchase date (purchase ticket or any other purchase proof will be requested). Guarantee does not include damages and breakage during the transport, damages and breakage due to faulty installation or improper use. Warranty is no longer valid when repairs or servicing have been made by unauthorized people or made with spare parts which are not original. Warranty does not include the complete replacement of the goods and refers exclusively to the replace of faulty pieces and necessary labour. It does not include transfer or transport expenses. The Customer will not ask for expenses refund.



## Description

Le compteur métrique **EV-030** permet l'affichage des mètres ou pieds de chaîne enroulés ou déroulés et la vitesse des ces opérations.

## Caractéristiques techniques

Tension d'alimentation	de 10 à 30 V DC
Absorption de courant	min. 5 mA – max. 40 mA
Degré de protection habillage partie frontale	IP65*
Température de fonctionnement	0°C à +70°C (32°F à 158 °F)
Moniteur graphique	128 x 64 pixels
Longueur maximum mesurable	999 mètres – 999 pieds
Dimensions (mm)	100 x 100 x 32**
Poids (g)	160

\* zone de connexion des câbles exclue - \*\* sans couvercle de protection



**Attention**

**ALIMENTER UNIQUEMENT EN COURANT CONTINU.**

## Notes générales

Le compteur métrique **EV-030** doit être utilisé pour la fonction décrite dans le présent manuel, à savoir pour l'actionnement et la visualisation des mètres/pieds de chaîne déroulés d'un guindeau. Toute autre utilisation doit être considérée comme impropre.

**Toute modification ou opération induite sur l'instrument entraîne l'annulation immédiate de la garantie.**

## Composants

### L'emballage contient:

- compteur métrique, joint et couvercle de fermeture;
- connecteur mâle dix pôles, avec 10 contacts mâle à sertir;
- capteur magnétique;
- kit support (support du capteur pour guindeau à axe vertical, base de soutien, 2 vis de fixation et joint torique);
- aimant;
- support capteur pour guindeau à axe horizontal;
- instructions d'utilisation.

## Installation

**Sur un nombre de modèles de guindeau le capteur et l'aimant sont déjà installés (configuration compteur métrique). Les opérations spécifiées ci-dessous ne doivent donc pas être effectuées.**

### Installation de l'aimant sur le guindeau

- Le trou à réaliser sur une dent du barbotin - d'un diamètre de 6,5 mm (~1/4") et d'une profondeur de 8 mm (5/16") - ne doit pas se trouver à hauteur d'une zone de passage de la chaîne.
- Pour les guindeaux à axe vertical (voir Fig. 1B), réaliser le trou sur la circonférence inférieure du barbotin.
- Pour les guindeaux à axe horizontal (voir Fig. 2B), réaliser le trou sur la circonférence externe du barbotin.
- S'assurer que la partie saillante de l'aimant ne heurte pas la base ni le capteur durant la rotation du barbotin.
- Introduire l'aimant dans le trou par la partie métallique en laissant dépasser d'environ 2 mm la partie protégée. Le fixer à l'aide d'une colle pour métaux (colle époxy bi-composant) ou à l'aide de silicone. La colle utilisée doit résister à l'environnement marin.

## Montage du capteur magnétique pour guindeau à axe vertical

(voir Fig. 1A – 1B)

- Réaliser sur le pont un trou de 4 mm de diamètre (~3/16") pour le passage du câble du capteur.
- Fixer l'élément A du support à l'aide des deux vis fournies à cet effet, après avoir positionné sur la partie inférieure de ce dernier le joint torique.
- Placer l'élément B, avec le capteur magnétique, sur le support A et en régler la hauteur de telle sorte qu'il soit aligné sur l'aimant fixé au barbotin.
- Placer le capteur à environ 3 mm (~1/8") de l'aimant et le fixer en serrant la vis G1. Serrer ensuite la vis G2.

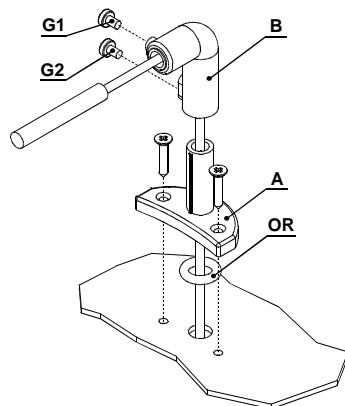

## Montage du capteur magnétique pour guindeau à axe horizontal

(voir Fig. 2A – 2B – 2C)

- Réaliser sur le pont un trou de 4 mm de diamètre (~3/16") pour le passage du câble du capteur.
- Fixer l'élément A du support à l'aide des deux vis fournies à cet effet, après avoir positionné sur la partie inférieure de ce dernier le joint torique.
- A l'aide d'une scie, couper l'élément C à la longueur nécessaire. Le capteur doit se trouver à environ 3 mm (~1/8") de l'aimant.
- Placer l'élément C, avec le capteur magnétique, sur le support A et le fixer à l'aide d'une colle pour matériaux plastiques (colle époxy bi-composant) ou à l'aide de silicone.
- A l'aide de la même colle ou de silicone, fixer le capteur à l'élément C.

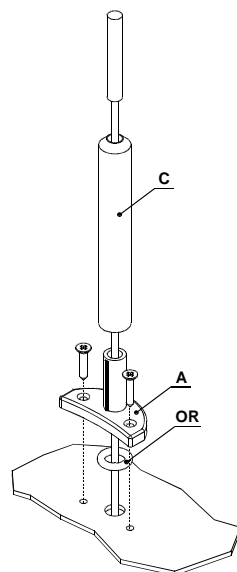

## Installation du compteur métrique

(voir schéma électrique)



### Attention

**VEILLER À DÉBRANCHER LA BATTERIE AVANT DE PROCÉDER À L'INSTALLATION.**

- Le compteur métrique doit être positionné de telle sorte que les indications affichées par le moniteur soient facilement lisibles évitant l'exposition aux rayons solaires.
- La partie postérieure du compteur métrique doit être à l'abri de l'eau et de l'humidité.
- L'instrument peut être fixé sur des tableaux de bord de n'importe quelle épaisseur. Pour la fixation utiliser des vis tarauds de 3,5 mm (~9/64") de diamètre et de 10 mm de longueur maximum plus l'épaisseur du tableau de bord.
- A l'arrière du tableau de bord, doit être disponible un espace d'au moins 35 mm (~1" 3/8). Un accès doit être en outre prévu pour l'installation et la maintenance.
- Sur le tableau de bord réaliser un trou de 30 mm de diamètre (~ 1" 3/16) et 4 trous de 4 mm (~5/32") pour les vis de fixation du compteur métrique. À l'aide d'une pince coupante éliminer les trois bornes sur la partie arrière de l'instrument, placer le compteur métrique et le fixer sur le tableau de bord et serrer les quatre vis. Lorsque sur le tableau de bord est déjà prévu un trou de 54 mm (2" 1/8) les bornes arrière ne doivent pas être coupées.
- Le joint doit être placé entre la partie antérieure du panneau du tableau de bord et l'instrument.

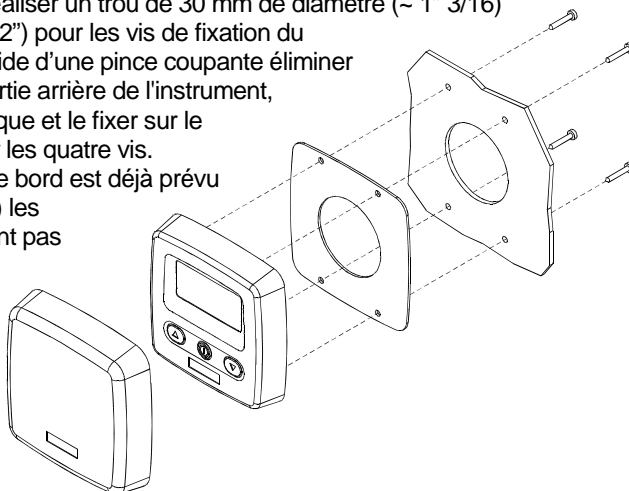

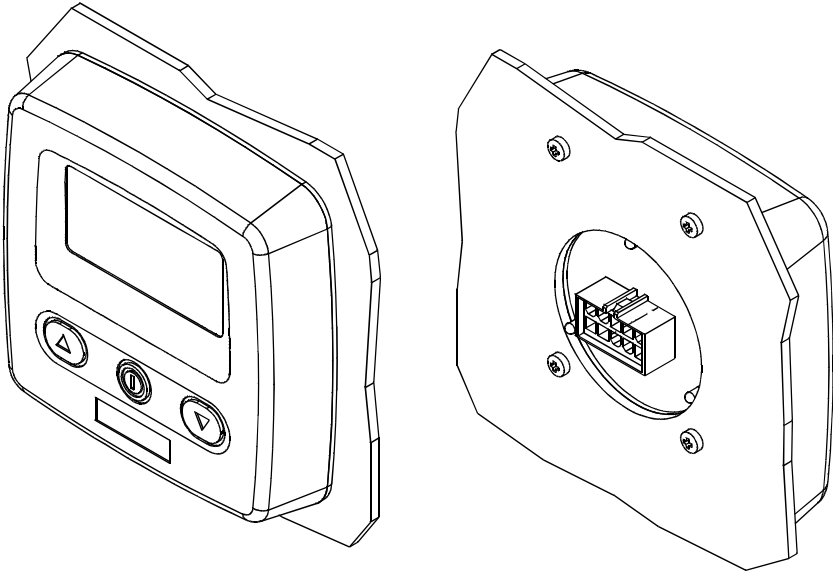

- Pour le branchement électrique, se reporter aux indications figurant sur le schéma joint en annexe. Les câbles doivent avoir une section d'au moins 1,5 mm<sup>2</sup>.
- Monter un fusible de protection de 4 A (ampère) sur le câble "+" de la batterie. Pour l'alimentation, ne pas utiliser le courant provenant du groupe de batteries moteurs.
- L'instrument répond aux standards EMC (EN55022) et doit se trouver à une distance d'au moins:
  - 30 cm (~1 pied) de la boussole;
  - 50 cm (~1,5 pieds) d'appareils radio;
  - 2 mètres (~6,5 pieds) de stations émettrices;
  - 2 mètres (~6,5 pieds) du faisceau radar.

## Branchements

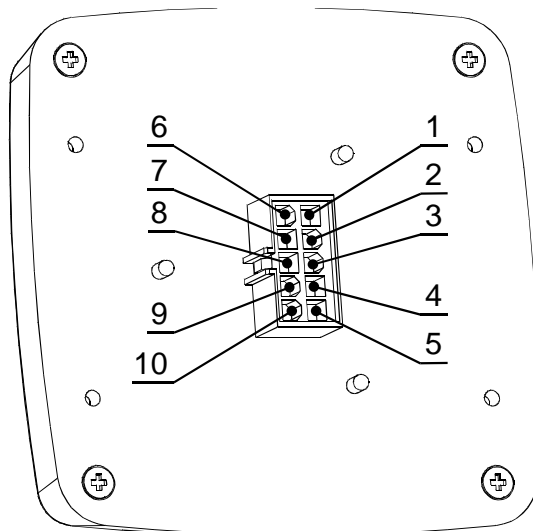

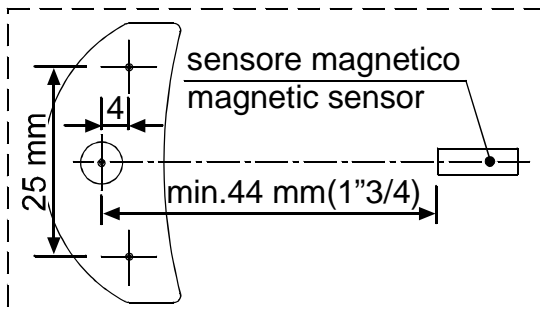
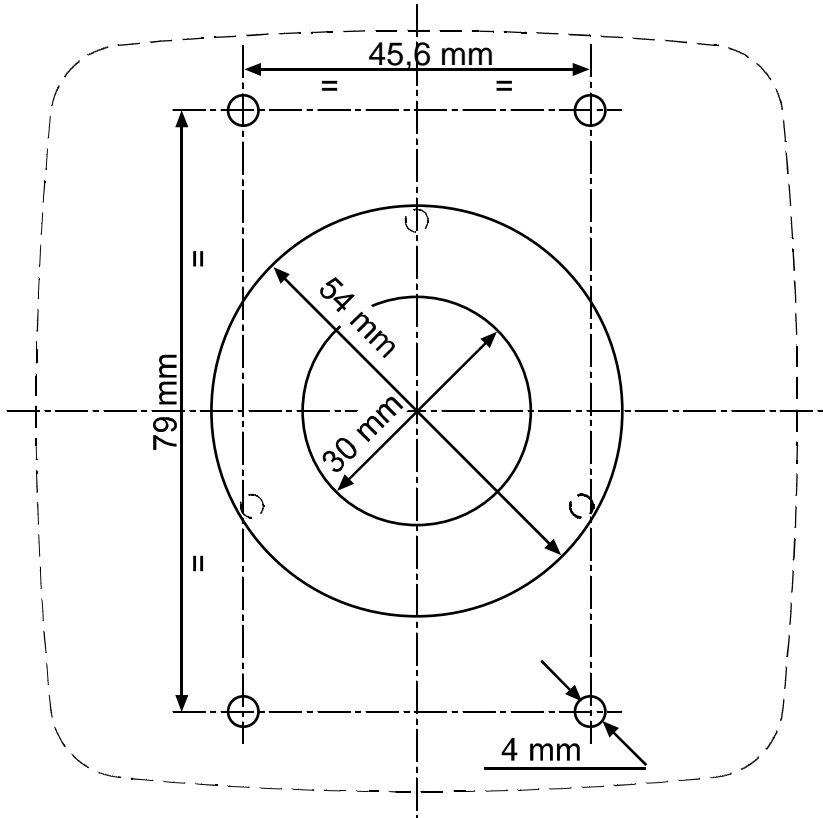

CONNECTEUR POSTÉRIEUR 10 PÔLES	
PIN	SIGNAL
1	+ Batterie
2	
3	- Batterie
4	
5	
6	Commande UP
7	Commande DOWN
8	
9	Entrée capteur Bout Chaîne
10	Capteur magnétique

## Perçage compteur métrique et capteur



## Premier allumage

Le compteur métrique est équipé d'un moniteur graphique et de trois touches:

 (**ON**),  (**UP**) et  (**DOWN**). Est également présent un avertisseur sonore qui signale la pression sur les touches ou attire l'attention de l'utilisateur en cas de conditions particulières (déclenchement alarmes).

La touche **ON** allume le moniteur et permet d'utiliser les deux autres touches. Il est utilisé pour avoir accès aux menus de sélection des paramètres, de modification des paramètres et de confirmation des valeurs sélectionnées. L'extinction de l'éclairage du moniteur se produit 30 secondes après la dernière commande utilisée (temps par défaut modifiable – voir « Temps BkLight »).

La touche **UP** commande la remontée de l'ancre, la touche **DOWN** la descente. La manœuvre s'interrompt si la touche est relâchée. Durant la sélection des paramètres, les deux touches permettent le mouvement à l'intérieur du menu et la variation des valeurs des paramètres.

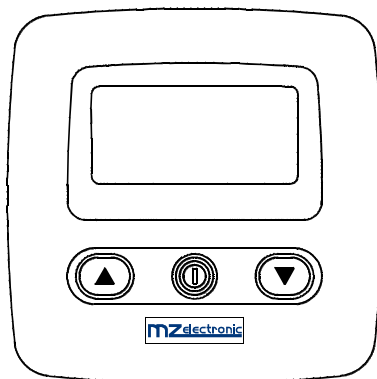

Lors de l'allumage de l'instrument on entend un beep sonore et apparaît pour quelques secondes la page suivante:





Une fois terminée la procédure d'initialisation, apparaît la page principale.



Où:

**ÉTAT:** indique l'état de l'instrument et les anomalies éventuelles.

**VITESSE:** indique la vitesse de la chaîne, remontée ou descente, en mètres ou pieds par minute.

**DÉCOMPTE:** indique la longueur de la chaîne descendue (mètres ou pieds).













**MONITORAGE:** indique la tension d'alimentation.

**ICÔNE:** il s'agit du secteur du moniteur où apparaissent les icônes indiquant la remontée ou la descente de l'ancre et les anomalies éventuelles.

Lors du premier allumage, l'instrument se positionne conformément à la programmation par défaut (voir tableau).

Paramètre	Valeur par défaut
Alarme montée	3.0 mètres
Descente automatique	Off
Temps BackLight	30 secondes
Unité de mesure	Mètres/centimètres
Mesure chaîne	0.0 mètres
Circonférence du Barbotin	33 cm
Type capteur	inconnu
Bip touches	Oui
Langue	Italien
Heures fonctionnement	0
Bout_Chaine	Off

## Menu de programmation du compteur métrique

<p>En maintenant enfoncée la touche  (ON), pendant six secondes, on a accès au menu de programmation de l'instrument. Sur le moniteur apparaît la page suivante:</p>	<div style="border: 1px solid black; padding: 5px;"> <p style="text-align: center;"><b>Menu</b></p> <p><b>Mesures</b></p> <p>A. et Fonctions</p> <p>Affich. personnels</p> <p>Langue</p> <p>Calibrage capteur</p> </div>
<p>Utiliser les touches  (DOWN) et  (UP) pour se déplacer à l'intérieur du menu.</p>	<div style="border: 1px solid black; padding: 5px;"> <p style="text-align: center;"><b>Menu</b></p> <p>Langue</p> <p><b>Calibrage capteur</b></p> <p>Controles</p> <p>Quitter</p> </div>
<p>Se porter sur la rubrique à modifier et appuyer sur la touche  (ON) pour valider le choix.</p>	
<p>Utiliser les touches  (DOWN) ou  (UP) pour se déplacer parmi les paramètres.</p>	
<p>Une fois choisi le paramètre appuyer sur la touche  (ON) pour activer la modification.</p>	
<p>En fonction du type de paramètre, utiliser les touches  (DOWN) et  (UP), pour réduire/augmenter la valeur ou désactiver/activer la fonction.</p>	
<p>Une fois la modification effectuée, appuyer sur la touche  (ON) pour valider.</p>	
<p>Au moyen de la touche  (DOWN) se porter sur la rubrique <b>Quitter</b> et appuyer de nouveau sur la touche  (ON) pour retourner au menu programmation. Suivre la même procédure pour retourner à la page principale.</p>	











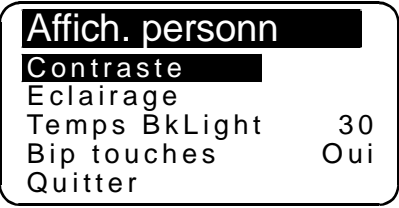



## Menu longueur





<div style="border: 1px solid black; padding: 10px; width: fit-content; margin: 0 auto;"> <div style="background-color: black; color: white; padding: 2px 10px; display: inline-block; font-weight: bold;">Mesures</div>  <div style="display: flex; justify-content: space-between; width: 100%;"> <span style="background-color: black; color: white; padding: 2px 10px;">Zerot.mesure</span> <span>No</span> </div> <div style="display: flex; justify-content: space-between; width: 100%;"> <span>Unite mesure</span> <span>Metres</span> </div> <div style="display: flex; justify-content: space-between; width: 100%;"> <span>Bout chaîne</span> <span>Off</span> </div> <div style="display: flex; justify-content: space-between; width: 100%;"> <span>Quitter</span> <span></span> </div> </div>	
<p>Utiliser les touches  (DOWN) ou  (UP) pour se déplacer parmi les paramètres.</p>	
<p><b>Zerot.mesure</b> Remet à zéro la longueur de la chaîne (0.0).</p>	<p>Sélectionner avec </p> <p> = Oui       = Non</p> <p>Valider avec </p>
<p><b>Unité de mesure</b> Sélectionne l'unité de mesure:</p> <p style="text-align: center; padding: 5px 0;">Pieds / pouces Mètres /centimètres</p>	<p>Sélectionner avec </p> <p> = Pieds       = Mètres</p> <p>Valider avec </p>
<p><b>Bout chaîne</b> On peut activer la fonction et sélectionner la valeur de commutation de bout à chaîne du capteur. Valeur sélectionnable de 0,1 à 25,0 (mètres ou pieds). Cette valeur correspond à la longueur de la chaîne. <b>Pour avoir cette fonction, installer le capteur CMCT-01 (en option).</b></p>	<p>Sélectionner avec </p> <p>Sélectionner la valeur au moyen de  </p> <p>Valider avec </p>
<p><b>Quitter</b> Pour revenir au menu de programmation.</p>	<p>Valider avec </p>

## Menu alarmes et fonctions







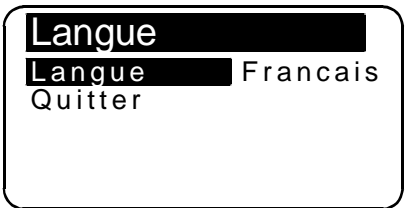

<div style="border: 1px solid black; padding: 10px; width: fit-content; margin: 0 auto;"> <div style="background-color: black; color: white; padding: 2px 10px; display: inline-block;"><b>A. et Fonctions</b></div>  <b>Alarme montée</b>      3.0  Descente aut.      Off  Info fabrique      No  Quitter </div>	
<p>Utiliser les touches  (DOWN) ou  (UP) pour se déplacer parmi les paramètres.</p>	
<p><b>Alarme montée</b>  On peut activer la fonction et établir la hauteur d'arrêt du guindeau. Après, seule la commande par impulsions est possible.  Valeur programmable. 1.0 - 1.5 - 2.0...5.0 (mètres ou pieds).</p>	<p>Sélectionner avec </p> <p>Sélectionner la valeur au moyen de   </p> <p>Valider avec </p>
<p><b>Descente automatique</b>  Active la procédure de descente automatique de l'ancre à la longueur désirée, par la pression (au moins 3 sec.) des touches  et .</p> <p>Valeur programmable. 5 - 10 - 15...40 (mètres ou pieds).</p>	<p>Sélectionner avec </p> <p>Sélectionner la valeur au moyen de   </p> <p>Valider avec </p>
<p><b>Info fabrique</b>  Cette fonction permet de rappeler les données d'origine par défaut, en <u>effaçant les données mémorisées.</u>  <b>Utiliser cette commande uniquement en cas d'erreur de programmation.</b></p>	<p>Sélectionner avec </p> <p> = Oui       = Non</p> <p>Valider avec </p>
<p><b>Quitter</b>  Pour revenir au menu de programmation.</p>	<p>Valider avec </p>

## Menu programmations







	
<p>Utiliser les touches  (DOWN) ou  (UP) pour se déplacer parmi les paramètres.</p>	
<p><b>Contraste</b> Cette fonction permet d'activer la procédure de sélection du contraste du moniteur.</p>	<p>Sélectionner avec </p> <p>Sélectionner la valeur au moyen de  </p> <p>Valider avec </p>
<p><b>Eclairage</b> Cette fonction permet d'activer la procédure de sélection de l'intensité de la lumière du moniteur.</p>	<p>Sélectionner avec </p> <p>Sélectionner la valeur au moyen de  </p> <p>Valider avec </p>
<p><b>Temps BackLight</b> Cette fonction permet de programmer le temps d'éclairage du moniteur après la dernière commande utilisée (valeur par défaut 30 secondes).</p>	<p>Sélectionner avec </p> <p>Sélectionner la valeur au moyen de  </p> <p>Valider avec </p>





<p><b>Bip touches</b>          Cette fonction permet d'activer ou désactiver le beep sonore produit à chaque pression des touches.</p>	<p>Sélectionner avec </p> <p> = Non       = Oui</p> <p>Valider avec </p>
<p><b>Quitter</b>          Pour revenir au menu de programmation.</p>	<p>Valider avec </p>

## Menu langue

	
<p>Utiliser les touches  (DOWN) ou  (UP) pour se déplacer parmi les paramètres.</p>	
<p><b>Langue</b>          On peut sélectionner la langue du moniteur:</p> <ul style="list-style-type: none"> <li>Italien</li> <li>Anglais</li> <li>Français</li> <li>Allemand</li> <li>Espagnol</li> </ul>	<p>Sélectionner avec </p> <p>Sélectionner la valeur au moyen de</p> <p> </p> <p>Valider avec </p>
<p><b>Quitter</b>          Pour revenir au menu de programmation.</p>	<p>Valider avec </p>

## Menu calibration capteur

<div style="border: 1px solid black; padding: 5px; width: fit-content; margin: 0 auto;"> <p><b>Calibrage capte</b></p> <p><b>Detect. Capt.</b></p> <p>Circ. Barbotin      33.0</p> <p>Quitter</p> </div>	
<p>Utiliser les touches  (DOWN) ou  (UP) pour se déplacer parmi les paramètres.</p>	
<p><b>Détection Capteur</b></p> <p>Cette fonction permet de calibrer l'instrument en fonction du type de capteur monté (Standard ou Project). La deuxième visualisation indique le temps pour une période d'utilisation du capteur et le type de capteur.</p>	<p>Sélectionner avec </p> <div style="border: 1px solid black; padding: 5px; width: fit-content; margin: 0 auto;"> <p><b>Detect. Capt.</b></p> <p>Appuyer UP ou DOWN Pour actionn. moteur</p> </div>
<p>Appuyer sur  ou </p>	
<div style="border: 1px solid black; padding: 5px; width: fit-content; margin: 0 auto;"> <p><b>Detect. Capt.</b></p> <p>Appuyer UP ou DOWN Pour actionn. moteur 0.400 sec. Capteur Std.</p> </div>	<div style="border: 1px solid black; padding: 5px; width: fit-content; margin: 0 auto;"> <p><b>Detect. Capt.</b></p> <p>Appuyer UP ou DOWN Pour actionn. moteur 0.400 sec. Capteur Proj.</p> </div>
<p>Valider avec </p>	

<p>Quand la procédure «Détection capteur» a relevé un capteur de type «Standard» plutôt qu'un capteur «Project», lors de l'accès ultérieur au menu «Calibrage Capteur» les rubriques du menu se «configurent» en fonction du capteur détecté.</p>	
<p style="text-align: center;"><b>Menu capteur Standard et Project série X.. (capteur et aimant appliqués dans le barbotin)</b></p> <div style="border: 1px solid black; padding: 5px; margin: 5px auto; width: 80%;"> <p style="text-align: center;"><b>Calibrage capte</b></p> <p style="text-align: center;">Circ. Barbotin      33.0</p> <p style="text-align: center;">Quitter</p> </div>	<p style="text-align: center;"><b>Menu capteur Project série 1000 – 1500 – 2000 W (capteur et aimant appliqués dans le moteur)</b></p> <div style="border: 1px solid black; padding: 5px; margin: 5px auto; width: 80%;"> <p style="text-align: center;"><b>Calibrage capte</b></p> <p style="text-align: center;">Facteur Red.      57.0</p> <p style="text-align: center;">Quitter</p> </div>
<p><b>Circonférence du Barbotin</b> Sur cette ligne il faut inscrire la circonférence du Barbotin (centimètres ou pouces). Pour le calcul de la circonférence, utiliser le <b>Tableau 1</b> en annexe. Valeur programmable: centimètres ou pouces. Valeur par défaut 33.</p>	<p><b>Facteur de Réduction</b> Sur cette ligne il faut inscrire le facteur de réduction. Pour le choix correct de la valeur à inscrire, faire référence au <b>Tableau 2</b> en annexe. Valeur par défaut 57.</p>
<p>Sélectionner avec </p> <p>Sélectionner la valeur au moyen de  </p> <p>Valider avec </p>	
<p><b>Quitter</b> Pour revenir au menu de programmation.</p>	<p>Valider avec </p>



**Tableau 1 - Capteur Standard et Project série X..**  
(capteur et aimant appliqués dans le barbotin)

Mesure chaîne	Nombre de renforcements	Circonférence du Barbotin (cm)	Circonférence du Barbotin (pouces)
6 mm	9	34	13
7 mm	6	25	9
8 mm	6	28	11
	7	33*	13
	8	38	15
10 mm	5	31	12
	6	36	14
12 mm	5	36	14
	6	43	17
13 mm	6	46	18
14 mm	5	42	16
3/8" BBB	7	38	15
3/8" HT	6	37	14
5/16" HT	7	36	14
1/2" BBB	6	40	16
1/2" HT	5	40	16





\* programmation par défaut de l'instrument



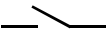

**Tableau 2 - Capteur Project série 1000 – 1500 – 2000W**  
(capteur et aimant appliqués dans le moteur)

Modèle	Circonférence du Barbotin (cm)	Rapport de réduction	Nombre de renforcements	Mesure chaîne (mm-pouces)	Facteur de Réduction
Project 1000	30	1:52	6	8-5/16"HT	57*
	30	1:52	5	10 DIN 766	
	31	1:52	5	10 ISO-3/8"HT	59
	34	1:52	9	6	65
Project 1500	30	1:70	6	8-5/16"HT	43
	30	1:70	5	10 DIN 766	43
	31	1:70	5	10 ISO-3/8"HT	44
	36	1:70	5	12 ISO-13 DIN 766-7/16"HT	51
Project 2000	39	1:75	6	3/8"HT	52
	40	1:75	6	3/8"Proof Coil	53
	41	1:75	6	10 DIN 766-3/8"BBB	54
	44	1:75	7	10 ISO	58
	45	1:75	5	14 ISO	60
	46	1:75	6	12 ISO-13 DIN 766	61
	47	1:75	5	13 DIN 764	63

\* programmation par défaut de l'instrument

## Menu Contrôles

<div style="border: 1px solid black; padding: 5px; width: fit-content; margin: 0 auto;"><p><b>Contrôles</b></p><p><b>Verif. Capt.</b></p><p>Verif. LCD</p><p>Version Sw.            1.01</p><p>Heures fonct.         0</p><p>Quitter</p></div>	
<p>Utiliser les touches  (DOWN) ou  (UP) pour se déplacer parmi les paramètres.</p>	
<p><b>Verif. Capteur</b></p> <p>Au moyen de cette fonction on peut contrôler l'état du capteur:</p> <p style="text-align: center;">contact ouvert</p>  <p style="text-align: center;">contact fermé</p>	<p style="text-align: right;">Sélectionner avec </p> <div style="border: 1px solid black; padding: 10px; margin: 10px auto; width: 80%;"><p><b>Test Capteur</b></p></div> <div style="border: 1px solid black; padding: 10px; margin: 10px auto; width: 80%;"><p><b>Test Capteur</b></p></div> <p style="text-align: right;">Valider avec </p>

<b>Verif. LCD</b> Cette fonction allume tous les pixel du moniteur et permet d'effectuer son contrôle.	Sélectionner avec   Valider avec 
<b>Version Software</b> Indique la version du logiciel.	
<b>Heures fonctionnement</b> Indique les heures de fonctionnement du treuil.	
<b>Quitter</b> Pour revenir au menu de programmation.	Valider avec 

## Calibrage de l'instrument

Avant d'utiliser l'instrument il faut programmer les paramètres suivants:

- choix de l'unité de mesure (mètres ou pieds);
- sélection de la fonction Bout\_Chaine (**capteur CMCT-01 en option**);

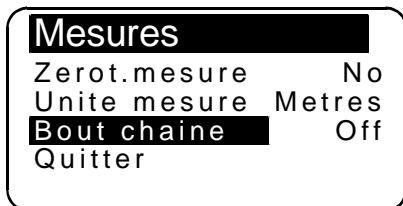

- détection du type de capteur (Standard ou Project);
- sélection de la circonférence du barbotin (valeur par défaut 33 cm) ou du facteur de réduction (valeur par défaut 57);

**Menu capteur Standard et Project série X..**



**Menu capteur Project série 1000 – 1500 – 2000 W**

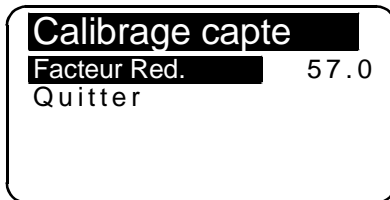

## Utilisation

Appuyer sur la touche  (**ON**) pour activer les commandes et éclairer le moniteur. L'extinction de l'éclairage du moniteur se produit 30 secondes après la dernière commande utilisée (temps par défaut modifiable – voir «Temps BkLight»).

En appuyant sur la touche  (**UP**) on commande la remontée de l'ancre.

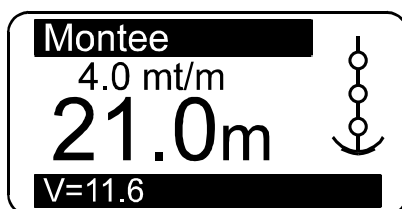



En appuyant sur la  (**DOWN**) on jette l'ancre.



En relâchant la touche de commande (**UP** ou **DOWN**), la manœuvre correspondante est interrompue.

### Remise à zéro de la longueur

Pour remettre à zéro le calcul de la longueur, appuyer sur la touche  (ON) et en même temps sur la touche  (UP) pendant au moins trois secondes.

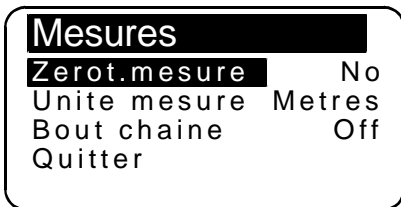

La remise à zéro de la longueur peut être effectuée à partir du menu **Longueur** en sélectionnant «Oui» sur la ligne **Zerot.mesure**.



### Décente automatique de l'ancre

Cette fonction doit être activée sur le menu **Alarmes et Fonctions** (la fonction est désactivée par défaut).



Sélectionner la fonction «**Descente aut.**» et sélectionner la hauteur à laquelle l'ancre doit s'arrêter. Après, appuyer sur la touche  (ON) et en même temps sur la touche  (DOWN) pendant au moins trois secondes. Une fois commencée la descente de l'ancre relâcher les touches.

**Pour des raisons de sécurité il est possible d'arrêter automatiquement à tout moment la descente en appuyant sur n'importe quelle touche.**

## Anomalies de fonctionnement

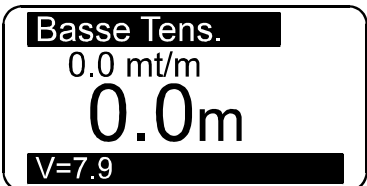
SYMPTÔME	CAUSE	INTERVENTION
	<p>Alors que la touche <b>UP</b> ou <b>DOWN</b> est enfoncée, l'instrument ne reçoit reçu aucun signal du capteur magnétique pendant plus de 5 secondes.</p>	<p>Vérifier les branchements électriques du capteur</p> <p>Vérifier le fonctionnement du capteur. S'il est abîmé, le remplacer.</p> <p>Vérifier la position du capteur et de l'aimant sur le barbotin et la distance entre les deux (3 mm).</p> <p>Vérifier le fonctionnement de l'installation électrique ou du guindeau.</p>
	<p>La tension d'alimentation de l'instrument est inférieure à 10V.</p>	<p>Vérifier l'état de charge de la batterie ou le fonctionnement de l'installation électrique.</p>

## Garantie

Nos produits sont certifiés contre les éventuels défauts de fabrication pendant deux ans à partir de la date d'achat (le ticket de caisse ou autre preuve d'achat feront foi). La garantie ne comprend pas: pannes et ruptures causées par le transport, interventions effectuées dues à mauvaise installation, pannes causées par emploi erroné de l'appareil. La garantie n'est pas valide en cas d'entretien ou réparation effectuées par des personnes qui ne sont pas autorisées, ou bien avec des rechanges qui ne sont pas originaux. La garantie ne prévoit pas en aucun cas le remplacement total de l'appareil; elle ne concerne que les pièces défectueuses et la manoeuvre. Elle ne comprend non plus les frais de transport et les éventuels frais de déplacement. Le Client ne pourra demander aucun remboursement des frais payés.

## Beschreibung

Der Meterzähler **EV-030** erlaubt, einen Anker mit der Anzeige in Metern oder Fuß der abgewickelten Kettenlänge und der Geschwindigkeit zu lichten oder auszuwerfen.

## Technische Merkmale

Anschlussspannung	von 10 bis 30 V DC
Stromaufnahme	min. 5 mA – max 40 mA
Schutzgrad Gehäusevorderseite	IP65*
Betriebstemperatur	0 / +70 °C (32 / 158 °F)
Graphisches <i>Display</i>	128 x 64 pixels
Max. erreichbares Maß	999 Meter – 999 Fuß
Abmessungen (mm)	100 x 100 x 32**
Gewicht (g)	160

\* ausgenommen der Kabelanschlussbereich - \*\* ohne Schutzdeckel



### **Achtung**

**AUSSCHLIESSLICH AN GLEICHSTROM ANSCHLIESSEN.**

## Allgemeine Hinweise

Der Meterzähler **EV-030** darf nur für die in diesem Handbuch beschriebenen Zwecke verwendet werden: Antrieb und Anzeige von Metern/Fuß einer von einem Ankerspill abgewickelten Kette. Jeder andere Gebrauch ist unzulässig.

**Mutwillige Änderungen am Instrument führen zum sofortigen Verfall der Garantie.**



## Komponenten

### Die Packung enthält:

- Meterzähler, Dichtung und Verschlussdeckel;
- 10poliger Stecker mit 10 Steckkontakten zum Crimpen;
- Magnetsensor;
- Halterungsbausatz (Sensorhalterung für Ankerspill mit vertikaler Achse, Unterlage, 2 Befestigungsschrauben, O-Ring);
- Magnet;
- Sensorhalterung für Ankerspill mit Horizontalachse;
- Gebrauchsanweisung.

## Installation

**Bei einigen Ankerspillmodellen sind Sensor und Magnet bereits installiert (Einrichtung für Meterzähler), deshalb müssen die nachstehenden Arbeitsgänge nicht ausgeführt werden.**

### Installation des Magneten im Ankerspill

- Das Bohrloch an einem Zahn der Kettennuss - Durchmesser 6,5 mm (~1/4") und Tiefe 8 mm (5/16") – muss an einer Stelle gebohrt werden, an der die Kette nicht durchläuft.
- Für das Ankerspill mit Vertikalachse (siehe Fig. 1B) muss die Bohrung im unteren Kreis der Kettennuss gebohrt werden.
- Für das Ankerspill mit Horizontalachse (siehe Fig. 2B) muss die Bohrung im äußeren Kreis der Kettennuss gebohrt werden.
- Es muss zudem überprüft werden, dass der hervorragende Teil des Magneten während der Drehung der Kettennuss die Unterlage oder den Sensor nicht berührt.
- Den Magneten mit dem Metallteil in das Bohrloch einsetzen und den geschützten Teil ca. 2 mm vorstehen lassen. Mit einem Metallkleber (Zweikomponenten-Epoxydkleber) oder Silikon befestigen. Der Kleber muss salzwasserbeständig sein.

## Montage des Magnetsensors für Ankerspill mit Vertikalachse

(siehe Fig. 1A – 1B)

- Ein Loch mit 4 mm ( $\sim 3/16''$ ) Durchmesser als Kabeldurchgang für den Sensor in das Deck bohren.
- Den O-Ring in den unteren Teil des Teils A der Halterung einsetzen und diese mit den zwei mitgelieferten Schrauben festschrauben.
- Das Teil B mit dem Magnetsensor auf die Halterung A montieren und in der Höhe so einstellen, dass dieser sich auf gleicher Achse wie der Magnet auf der Kettennuss befindet.
- Den Sensor bis ca. 3 mm ( $\sim 1/8''$ ) an den Magnet annähern und mit der Schraube G1 festschrauben. Danach die Schraube G2 anziehen.

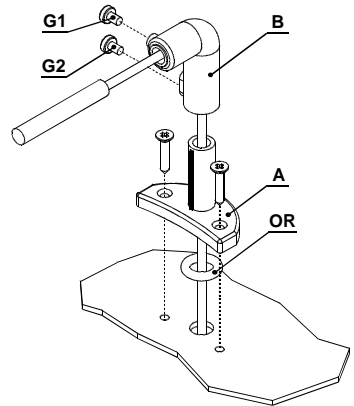

## Montage des Magnetsensors für Ankerspill mit Horizontalachse

(siehe Fig. 2A – 2B – 2C)

- Ein Loch mit 4 mm ( $\sim 3/16''$ ) Durchmesser als Kabeldurchgang für den Sensor in das Deck bohren.
- Den O-Ring in den unteren Teil des Teils A der Halterung einsetzen und diese mit den zwei mitgelieferten Schrauben festschrauben.
- Das Teil C mit einer Säge zuschneiden. Der Sensor muss ca. 3 mm ( $\sim 1/8''$ ) vom Magnet entfernt positioniert werden.
- Das Teil C mit dem Magnetsensor auf die Halterung A montieren und mit einem Metallkleber (Zweikomponenten-Epoxydkleber) oder Silikon befestigen.
- Mit dem gleichen Kleber den Sensor an das Teil C befestigen.

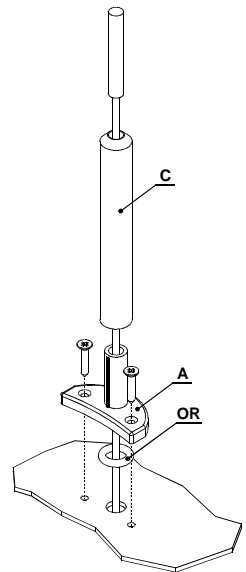

## Installation des Meterzählers

(siehe Stromlaufplan)



### Achtung

**VOR DER INSTALLATION DIE BATTERIE IMMER ABKLEMMEN.**

- Der Meterzähler muss so positioniert sein, dass das Display gut ablesbar und nicht dem Sonnenlicht ausgesetzt ist.
- Die Rückseite des Meterzählers muss vor Wasser und Feuchtigkeit geschützt sein.
- Das Instrument kann an Armaturenbrettern mit beliebiger Wandstärke montiert werden. Die Befestigungsschrauben müssen selbstschneidend sein, sowie einen Durchmesser von 3,5 mm (~9/64") und eine max. Länge von 10 mm plus die Wandstärke des Armaturenbretts aufweisen.
- Auf der Rückseite des Armaturenbretts muss mindestens 35 mm (1" 3/8) Platz vorhanden sein. Zudem muss ein Zugang für die Installations- und Wartungsarbeiten vorhanden sein.
- In der Armaturenbrett angegeben ein Loch mit 30 mm (~ 1" 3/16) Durchmesser und 4 mit 4 mm (~5/32") Durchmesser für die Befestigungsschrauben des Meterzählers bohren. Mit einer Schneidezange die drei Sprossen auf der Rückseite des Instruments abschneiden, den Meterzähler anbringen und mit den vier Schrauben am Armaturenbrett festschrauben. Falls im Instrumentenbrett bereits eine Aufnahme von 54 mm (2"1/8) Durchmesser vorhanden ist, müssen die Sprossen nicht abgeschnitten werden.
- Die Dichtung muss zwischen die Vorderseite des Armaturenbretts und das Instrument eingelegt werden.

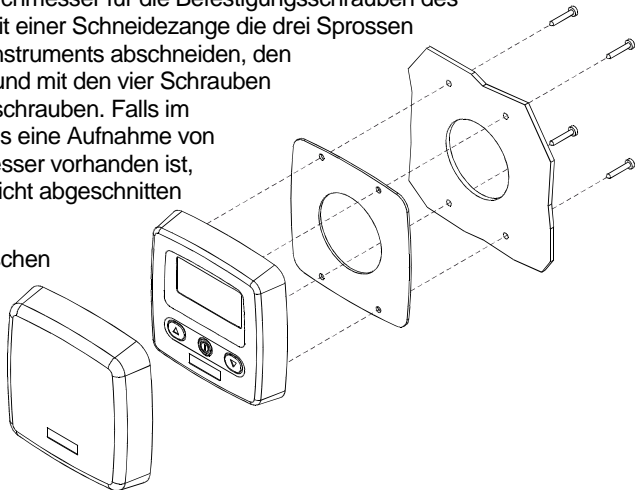

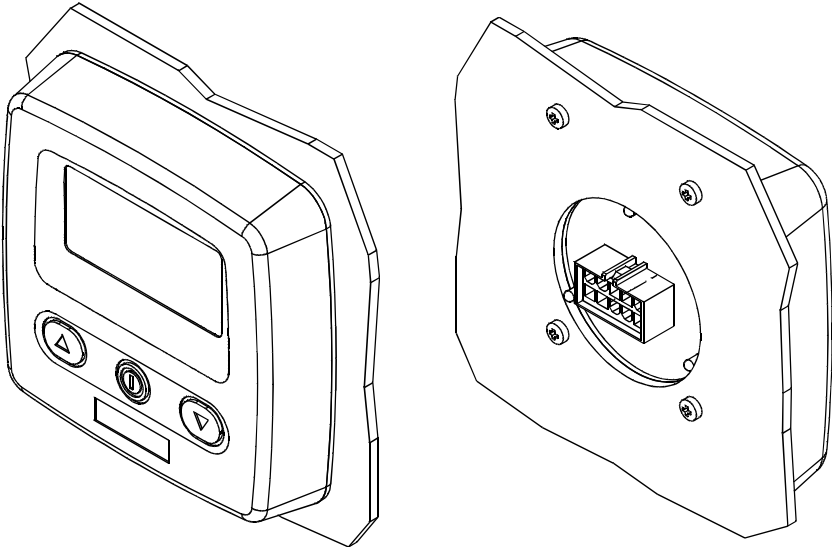

- Für den Stromanschluss sind die Anweisungen des beiliegenden Stromlaufplans zu befolgen. Die Kabel müssen einen Mindestquerschnitt von 1,5 mm<sup>2</sup> aufweisen.
- Eine flinke 4 A (Ampere) Sicherung auf das Kabel + der Batterie montieren. Für die Stromzufuhr nicht die Spannung von den Motorbatterien verwenden.
- Das Instrument entspricht den EMC-Standards (EN55022) und muss mindestens:
  - 30 cm (~1 Ft) vom Kompass,
  - 50 cm (~1,5 Ft) von Funkempfängern,
  - 2 Meter (~6,5 Ft) von Funksendern,
  - 2 Meter (~6,5 Ft) vom Radarstrahl.

## Anschlüsse

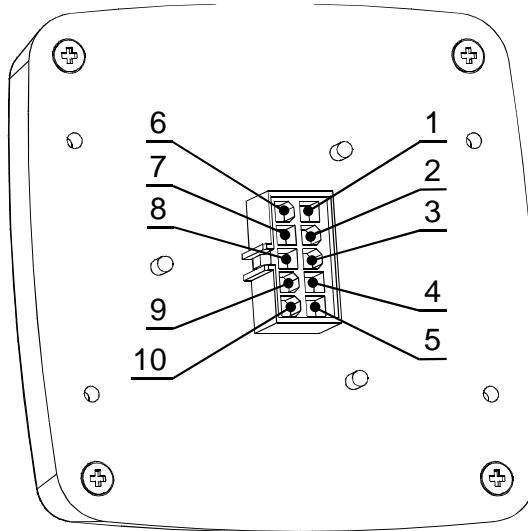

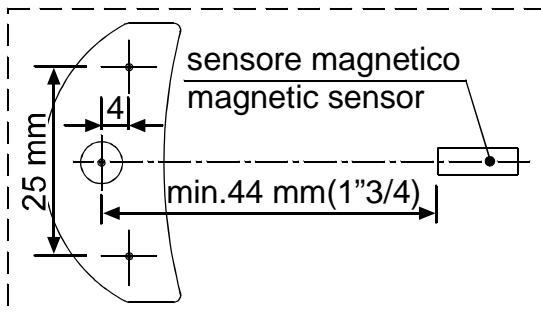
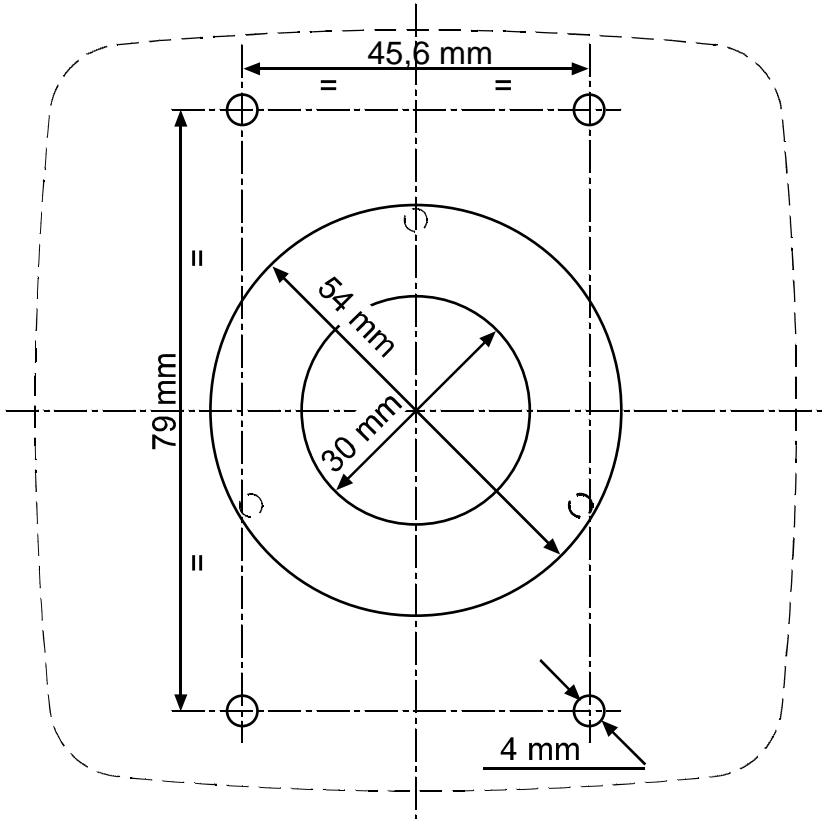

HINTERE 10 POLIGE STECKVERBINDUNG	
PIN	SIGNAL
1	+ Batterie
2	
3	- Batterie
4	
5	
6	Steuerung UP
7	Steuerung DOWN
8	
9	Sensoreingang Tau_Kette
10	Magnetsensor

**Bohr Meterzähler und Sensor**



## Werkseinstellung des Instruments

Der Meterzähler ist mit einem graphischen *Display* und drei Tasten ausgerüstet:  (**ON**),  (**UP**) und  (**DOWN**). Zudem ist ein *Summer* vorhanden, der den Tastendruck meldet oder den Benutzer auf besondere Zustände (Alarmauslösungen) aufmerksam macht.

Die Taste **ON** schaltet das *Display* ein und die anderen beiden Tasten frei. Sie wird für den Zugriff zu den Eingabemenüs der Parameter, die Auswahl der zu ändernden Parameter und die Bestätigung der Eingabewerte verwendet. Die Beleuchtung des *Displays* schaltet 30 Sekunden nach dem letzten Steuerbefehl aus (änderbare *Default-Zeit* – siehe “Zeit BkLight”).

Die Taste **UP** steuert das Lichten des Ankers und die Taste **DOWN** das Auswerfen. Sobald die Taste losgelassen wird, stoppt die entsprechende Bewegung. In der Parametereingabephase kann das Menü mit den beiden Tasten durchlaufen und die Änderung der Parameterwerte vorgenommen werden.

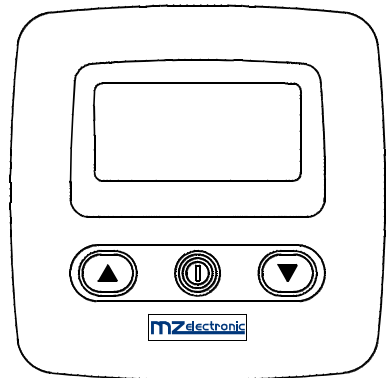

Beim Einschalten des Instruments ertönt ein akustisches Signal und ein paar Sekunden lang erscheint die folgende Seite:



Nach Beendigung der Initialisierung erscheint die Hauptseite.

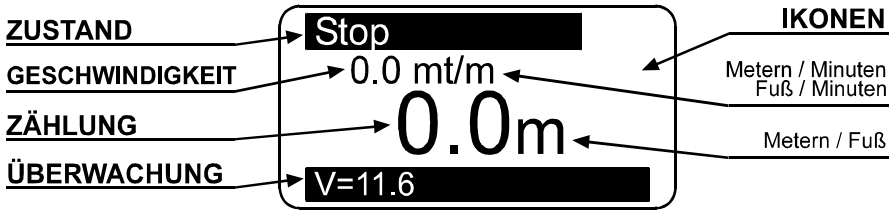

Mit folgenden Angaben:

**ZUSTAND:** Zustand es Instruments und eventuelle Störungen.

**GESCHWINDIGKEIT:** Kettengeschwindigkeit in beiden Richtungen, in Metern oder Fuß pro Minute.

**ZÄHLUNG:** Länge der ausgeworfenen Kette (Metern oder Fuß).

**ÜBERWACHUNG:** Anschlussspannung.













**IKONEN:** In diesem Teil des *Displays* erscheinen die Ikonen, die das Lichten oder Auswerfen des Ankers und eventuelle Störungen anzeigen.

Beim erstmaligen Einschalten stellt sich das Instrument auf die Werkseinstellungen ein (siehe Tabelle).















Parameter	Defaulteinstellung
Fierenalarm	3.0 Meter
Automatisches Abstieg	Off
BackLight Zeit	30 Sekunden
Maßeinheit	Meter / Zentimeter
Kettenmaß	0.0 Meter
Kettenusskreis	33 cm
Typ sensor	unbekannt
Tastenton	Ja
Sprache	Italienisch
Betriebszeit	0
Tau_Kette	Off



## Einstellmenü des Meterzählers

<p>Die Taste  (<b>ON</b>) für den Zugriff zum Einstellmenü des Instruments sechs Sekunden lang drücken. Auf dem <i>Display</i> erscheint folgende Seite:</p>	<div style="border: 1px solid black; padding: 5px;"> <p><b>Menu</b></p> <p><b>Mab</b></p> <p>Funktionen</p> <p>Pers.Einstel</p> <p>Sprache</p> <p>Kalibrierung</p> </div>
<p>Mit der Taste  (<b>DOWN</b>) und  (<b>UP</b>) zu den verschiedenen Menüpositionen springen.</p>	<div style="border: 1px solid black; padding: 5px;"> <p><b>Menu</b></p> <p>Sprache</p> <p><b>Kalibrierung</b></p> <p>Kontrolle</p> <p>Ausgang</p> </div>
<p>Wenn die zu ändernde Position erreicht ist, die Taste  (<b>ON</b>) zur Bestätigung der Auswahl drücken.</p>	
<p>Mit den Tasten  (<b>DOWN</b>) oder  (<b>UP</b>) zu den verschiedenen Parametern springen.</p>	
<p>Wenn der gewünschte Parameter erreicht ist, die Taste  (<b>ON</b>) zur Freischaltung der Änderung drücken.</p>	
<p>Je nach Art des Parameter die Taste  (<b>DOWN</b>) und  (<b>UP</b>) benutzen und den Wert nach oben/unten ändern oder die Funktion aus-/freischalten.</p>	
<p>Wenn die Änderung ausgeführt ist, mit der Taste  (<b>ON</b>) bestätigen.</p>	
<p>Mit der Taste  (<b>DOWN</b>) auf die Position <b>Ausgang</b> springen und die Taste  (<b>ON</b>) für die Rückkehr zum Einstellmenü nochmals drücken. Auf die gleiche Weise kehrt man zur Hauptseite zurück.</p>	

## Mess-Menü





<div style="border: 1px solid black; padding: 5px; width: fit-content; margin: 0 auto;"> <p><b>Mab</b></p> <p><b>Massnulleinst</b>    Nein</p> <p>Masseinheit    Meter</p> <p>Tau Kette    Off</p> <p>Ausgang</p> </div>	
<p>Mit der Taste  (<b>DOWN</b>) und  (<b>UP</b>) zu den verschiedenen Parametern springen.</p>	
<p><b>Massnulleinst</b> Setzt das Kettenmaß auf Null zurück (0.0).</p>	<p>Anwählen mit </p> <p> = Ja       = Nein</p> <p>Bestätigen mit </p>
<p><b>Maßeinheit</b> Auswahl der Maßeinheit:</p> <p style="text-align: center;">Fuß / Zoll Meter / Zentimeter</p>	<p>Anwählen mit </p> <p> = Fuß       = Meter</p> <p>Bestätigen mit </p>
<p><b>Tau Kette</b> Diese Funktion kann frei geschaltet und der Wert eingestellt werden, bei dem der Sensor von Tau auf Kette umschalten soll. Einstellwertbereich von 0.1 bis 25.0 (Meter oder Fuß). Dieser Wert entspricht der Kettenlänge. <b>Für diese Funktion muss der Sensor CMCT-01 (Option) montiert werden.</b></p>	<p>Anwählen mit </p> <p>Wert einstellen mit  </p> <p>Bestätigen mit </p>
<p><b>Ausgang</b> Zur Rückkehr in das Einstellmenü.</p>	<p>Bestätigen mit </p>

## Menü Alarmer und Funktionen







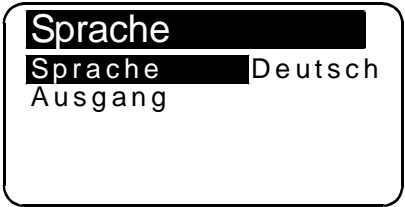

<div style="border: 1px solid black; padding: 5px; width: fit-content; margin: 0 auto;"> <div style="background-color: black; color: white; padding: 2px 5px; display: inline-block;"><b>Funktionen</b></div>  <b>Fierenalarm</b>            3.0          Autom. Abstieg        Off          Fabrikdaten            Nein          Ausgang       </div>	
Mit der Taste  ( <b>DOWN</b> ) und  ( <b>UP</b> ) zu den verschiedenen Parametern springen.	
<b>Fierenalarm</b> Die Funktion kann frei geschaltet und das Maß festgelegt werden, bei dem das Ankerspill stoppt. Danach ist nur noch die Tipsteuerung möglich. Einstellwert: 1.0 - 1.5 - 2.0...5.0 (Meter oder Fuß).	Anwählen mit Wert einstellen mit Bestätigen mit
<b>Automatisches Abstieg</b> Schaltet durch Drücken während min. 3 Sek. der Tasten  und  das automatische Auswerfen des Ankers auf das gewünschte Maß frei. Einstellwert: 5 - 10 - 15...40 (Meter oder Fuß).	Anwählen mit Wert einstellen mit Bestätigen mit
<b>Fabrikdaten</b> Diese Funktion ermöglicht den Aufruf der ursprünglichen Werkseinstellungen und <u>löscht alle gespeicherten Einstellungen</u> . <b>Diese Steuerfunktion nur bei falscher Programmierung verwenden.</b>	Anwählen mit = Ja       = Nein Bestätigen mit
<b>Ausgang</b> Zur Rückkehr in das Einstellmenü.	Bestätigen mit

## Einstellmenü







<div style="border: 1px solid black; padding: 5px; width: fit-content; margin: 0 auto;"> <div style="background-color: black; color: white; padding: 2px 5px; display: inline-block;"><b>Pers.Einstel</b></div>  <div style="background-color: black; color: white; padding: 2px 5px; display: inline-block;"><b>LCDKontrast</b></div>  LCD Litch <span style="float: right;">30</span>  BkLight Zeit <span style="float: right;">Ja</span>  Tastenton  Ausgang </div>	
<p>Mit der Taste  (<b>DOWN</b>) und  (<b>UP</b>) zu den verschiedenen Parametern springen.</p>	
<p><b>LCDKontrast</b>  Durch Freischaltung dieser Funktion kann das Programmierverfahren des Kontrasts des <i>Displays</i> frei geschaltet werden.</p>	<p>Anwählen mit </p> <p>Wert einstellen mit  </p> <p>Bestätigen mit </p>
<p><b>LCD Litch</b>  Durch Freischaltung dieser Funktion kann das Programmierverfahren der Lichtstärke des <i>Displays</i> frei geschaltet werden.</p>	<p>Anwählen mit </p> <p>Wert einstellen mit  </p> <p>Bestätigen mit </p>
<p><b>BackLight Zeit</b>  Mit dieser Funktion kann die Zeit eingestellt werden, während der das <i>Display</i> nach dem letzten Steuerbefehl beleuchtet bleibt (Default-Wert 30 Sekunden).</p>	<p>Anwählen mit </p> <p>Wert einstellen mit  </p> <p>Bestätigen mit </p>

<p><b>Tastenton</b> Diese Funktion erlaubt die frei- oder Ausschaltung des <i>Summers</i> (Piepston bei jedem Tastendruck).</p>	<p>Anwählen mit </p> <p> = Nein       = Ja</p> <p>Bestätigen mit </p>
<p><b>Ausgang</b> Zur Rückkehr in das Einstellmenü.</p>	<p>Bestätigen mit </p>





## Sprachmenü

	
<p>Mit der Taste  (<b>DOWN</b>) und  (<b>UP</b>) zu den verschiedenen Parametern springen.</p>	
<p><b>Sprache</b> Die Sprache des <i>Displays</i> kann ausgewählt werden:</p> <ul style="list-style-type: none"> <li>Italiano</li> <li>English</li> <li>Français</li> <li>Deutsch</li> <li>Español</li> </ul>	<p>Anwählen mit </p> <p>Wert einstellen mit  </p> <p>Bestätigen mit </p>
<p><b>Ausgang</b> Zur Rückkehr in das Einstellmenü.</p>	<p>Bestätigen mit </p>

## Menü Sensorkalibrierung

<div style="border: 1px solid black; padding: 5px; width: fit-content; margin: 0 auto;"> <p><b>Kalibrierung</b></p> <p><b>Sensormessung</b></p> <p>Kettenusskreis      33.0</p> <p>Ausgang</p> </div>	
<p>Mit der Taste  (DOWN) und  (UP) zu den verschiedenen Parametern springen.</p>	
<p><b>Sensormessung</b></p> <p>Mit dieser Funktion kann das Instrument je nach montiertem Sensortyp (Standard oder Project) kalibriert werden.</p> <p>Die zweite Seite zeigt die Zeit für einen Zeitabschnitt des Sensors und den Sensortyp an.</p>	<p>Anwählen mit </p> <div style="border: 1px solid black; padding: 5px; margin-top: 10px;"> <p><b>Sensormessung</b></p> <p>UP o. DOWN drücken</p> <p>Motor einstellen</p> </div>
<p> oder  drücken</p>	
<div style="border: 1px solid black; padding: 5px;"> <p><b>Sensormessung</b></p> <p>UP o. DOWN drücken</p> <p>Motor einstellen</p> <p>0.400 sec.</p> <p>Standardsensor</p> </div>	<div style="border: 1px solid black; padding: 5px;"> <p><b>Sensormessung</b></p> <p>UP o. DOWN drücken</p> <p>Motor einstellen</p> <p>0.400 sec.</p> <p>Projectsensor</p> </div>
<p>Bestätigen mit </p>	

Wenn die Sensorerfassungsroutine einmal einen Sensor des Typs "Standard" anstelle des "Project" erfasst hat, passen sich die Menüpositionen beim nächsten Zugriff zum Menü "Kalibrierung" automatisch dem gefundenen Sensor an.

<b>Menü Sensor Standard und Project serien X..</b> (sensor und magnet in <u>den barbotin angebracht</u> )	<b>Menü Sensor Project serien 1000 – 1500 – 2000 W</b> (sensor und magnet in <u>den motor angebracht</u> )
<div style="border: 1px solid black; padding: 5px; margin-bottom: 5px;"> <p style="background-color: black; color: white; padding: 2px;"><b>Kalibrierung</b></p> <p style="background-color: black; color: white; padding: 2px;">Kettenuusskreis 33.0</p> <p>Ausgang</p> </div>	<div style="border: 1px solid black; padding: 5px; margin-bottom: 5px;"> <p style="background-color: black; color: white; padding: 2px;"><b>Kalibrierung</b></p> <p style="background-color: black; color: white; padding: 2px;">Red. Faktor 57.0</p> <p>Ausgang</p> </div>
<p><b>Kettenuusskreis</b>          In diese Zeile wird der Kettenuussumfang (in Zentimetern oder Zoll) eingegeben. Zur Berechnung des Umfangs die anliegende <b>Tabelle 1</b> verwenden.          Einstellwert: Zentimeter oder Zoll.          Defaulteinstellung auf 33 cm.</p>	<p><b>Red.Faktor</b>          In diese Zeile wird der Reduktion Faktor. Zur Auswahl des richtigen Einstellwerts die nachstehende <b>Tabelle 2</b> nachsehen.          Defaulteinstellung des Werts 57.</p>
<p>Anwählen mit </p> <p>Wert einstellen mit  </p> <p>Bestätigen mit </p>	
<p><b>Ausgang</b>          Zur Rückkehr in das Einstellmenü.</p>	Bestätigen mit 

**Tabelle 1 - Sensor Standard und Project serien X..**  
**(sensor und magnet in den barbotin angebracht)**

Kettentyp	Anzahl Aussparungen	Umfang Kettennuss (cm)	Umfang Kettennuss (Zoll)
6 mm	9	34	13
7 mm	6	25	9
8 mm	6	28	11
	7	33*	13
	8	38	15
10 mm	5	31	12
	6	36	14
12 mm	5	36	14
	6	43	17
13 mm	6	46	18
14 mm	5	42	16
3/8" BBB	7	38	15
3/8" HT	6	37	14
5/16" HT	7	36	14
1/2" BBB	6	40	16
1/2" HT	5	40	16

\* Werkseinstellung des Instruments







**Tabelle 2 - Sensor Project serien 1000 – 1500 – 2000W**  
**(sensor und magnet in den motor angebracht)**



Modell	Umfang Kettennuss (cm)	Untersetzung-verhältnis	Anzahl Aussparungen	Kettenmass (mm-Zoll)	Red. Faktor
Project 1000	30	1:52	6	8-5/16"HT	57*
	30	1:52	5	10 DIN 766	
	31	1:52	5	10 ISO-3/8"HT	59
	34	1:52	9	6	65
Project 1500	30	1:70	6	8-5/16"HT	43
	30	1:70	5	10 DIN 766	43
	31	1:70	5	10 ISO-3/8"HT	44
	36	1:70	5	12 ISO-13 DIN 766-7/16"HT	51
Project 2000	39	1:75	6	3/8"HT	52
	40	1:75	6	3/8"Proof Coil	53
	41	1:75	6	10 DIN 766-3/8"BBB	54
	44	1:75	7	10 ISO	58
	45	1:75	5	14 ISO	60
	46	1:75	6	12 ISO-13 DIN 766	61
	47	1:75	5	13 DIN 764	63

\* Werkseinstellung des Instruments

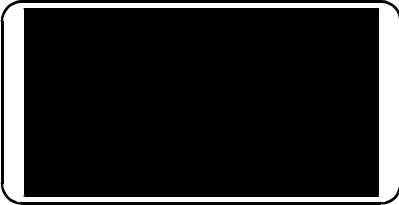

## Menü Überprüfungen

<div style="border: 1px solid black; padding: 5px; width: fit-content; margin: auto;"><b>Kontrolle</b> <b>Sensor Test</b> LCD Test Sw. Version            1.01 Betriebszeit            0 Ausgang</div>	
Mit der Taste  ( <b>DOWN</b> ) und  ( <b>UP</b> ) zu den verschiedenen Parametern springen.	
<b>Sensor Test</b> Diese Funktion überprüft den Zustand des Sensors:  Kontakt offen          Kontakt geschlossen	<p>Anwählen mit </p> <div style="border: 1px solid black; padding: 10px; margin: 10px auto; width: 80%;"><b>Sensor Test</b>  </div> <div style="border: 1px solid black; padding: 10px; margin: 10px auto; width: 80%;"><b>Sensor Test</b>  </div> <p>Bestätigen mit </p>

<p><b>LCD Test</b>          Diese Funktion schaltet alle <i>Pixel</i> des <i>Displays</i> zur Überprüfung ein.</p>	<p>Anwählen mit </p>  <p>Bestätigen mit </p>
<p><b>Sw. Version</b>          Anzeige der <i>Software</i>-Version.</p>	
<p><b>Betriebszeit</b>          Anzeige der Betriebsstunden des Ankerspills.</p>	
<p><b>Ausgang</b>          Zur Rückkehr in das Einstellmenü.</p>	<p>Bestätigen mit </p>

## Kalibrierung des Instruments

Bevor das Instrument verwendet wird, müssen folgende Parameter eingegeben werden:

- Auswahl der Maßeinheit (Meter oder Fuß);
- Einstellung der Funktion Tau\_Kette (**Sensor CMCT-01 Option**);

**Mab**

Massnulleinst	Nein
Masseinheit	Meter
<b>Tau Kette</b>	Off
Ausgang	

- Erfassung des Sensortyps (Standard oder Project);
- Einstellung des Kettennussdurchmessers (*Default 33 cm*) oder Red. Faktor (*Default 57*);

**Menü Sensor Standard und  
Project serien X..**

**Kalibrierung**

Kettennusskreis	33.0
Ausgang	

**Menü Sensor Project serien  
1000 – 1500 – 2000 W**

**Kalibrierung**

Red. Faktor	57.0
Ausgang	

## Gebrauch

Die Taste  (**ON**) zur Aktivierung der Steuerungen und Beleuchtung des *Displays* drücken. Die *Display*-Beleuchtung wird 30 Sekunden nach dem letzten Steuerbefehl ausgeschaltet (änderbare *Default*-Zeit– siehe "Zeit BkLight").

Die Taste  (**UP**) steuert das Lichten des Ankers.

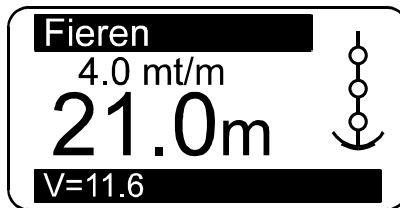



Die Taste  (**DOWN**) steuert das Auswerfen.



Sobald die Taste (**UP** oder **DOWN**) losgelassen wird, stoppt die entsprechende Bewegung.

## Maß-Reset

Zum Zurücksetzen der Maß-Zählung die Taste  (**ON**) und gleichzeitig die Taste  (**UP**) mindestens drei Sekunden lang drücken.



Die Maßzurücksetzung kann auch im **Mess**-Menü durch Anwählen von “**Ja**” in der Zeile **Maßnulleinst** erfolgen.

<b>Maß</b>	
<b>Massnulleinst</b>	Nein
Masseinheit	Meter
Tau Kette	Off
Ausgang	

## Automatisches Auswerfen des Ankers

Diese Funktion muss im Menü **Alarme und Funktionen** frei geschaltet werden (per *Default* ist die Funktion ausgeschaltet).

<b>Funktionen</b>	
Fierenalarm	3.0
<b>Autom. Abstieg</b>	Off
Fabrikdaten	Nein
Ausgang	

“**Autom. Abstieg**” anwählen und den gewünschten Stoppwert des Ankers eingeben. Nach der Eingabe des Masses die Taste  (**ON**) und gleichzeitig die Taste  (**DOWN**) mindestens drei Sekunden lang drücken. Sobald der Anker in Bewegung ist, die Tasten loslassen.

**Aus Sicherheitsgründen kann das automatische Auswerfen des Ankers durch Drücken einer beliebigen Taste des Instruments unterbrochen werden.**

## Betriebsstörungen

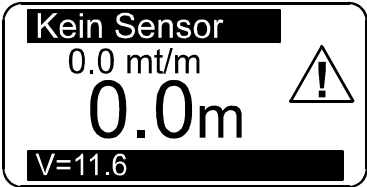
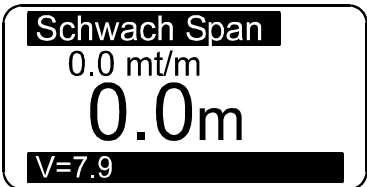
MELDUNG	URSACHE	BEHEBUNG
	<p>Während die Taste <b>UP</b> oder <b>DOWN</b> gedrückt wurde, hat das Instrument mehr als 5 Sekunden lang kein Signal vom Magnetsensor erhalten.</p>	<p>Die Stromanschlüsse des Sensors überprüfen.</p> <p>Die Funktionsweise des Sensors überprüfen und diesen eventuell ersetzen.</p> <p>Die Position des Sensors, des Magnets auf der Kettennuss und den Abstand zwischen den beiden (3 mm) überprüfen.</p> <p>Die Funktionsweise der elektrischen Anlage oder des Ankerspills überprüfen.</p>
	<p>Die Anschlussspannung des Instruments ist niedriger als 10V.</p>	<p>Den Ladezustand der Batterie oder die Funktionsweise der elektrischen Ausrüstung kontrollieren.</p>

## Garantie

Unsere Artikel haben eine Garantie gegen Produktionsfehler von 2 Jahre ab dem Kaufdatum (Kassenbono oder anderer Kaufbeleg). In der Garantie sind nicht enthalten: Störungen oder Beschädigungen durch den Transport, Eingriffe wegen falscher Installation, Störungen durch falscher Anwendung des Apparates. Die Garantie entfällt falls die Reparatur durch von der Firma nicht autorisierte Personen oder mit nicht originalen Ersatzteilen erfolgt. Die Garantie sieht auf keinen Fall den kompletten Ersatz des Apparates. Die Garantie haftet nur für mangelhafte Teile und der relativen Arbeitszeit. Sie deckt nicht den Transport oder die Aufwandsentschädigung. Der Kunde kann keine Erstattung der Unkosten verlangen.

## Descripción

El cuentametros **EV-030** permite zarpar o tirar el ancla con la visualización de los metros o pies de cadena desenrollada y de la velocidad de la misma.

## Datos técnicos

Tensión de alimentación	entre 10 y 30 V DC
Consumo de corriente	mín. 5 mA / máx. 40 mA
Grado de protección envoltorio parte frontal	IP65*
Temperatura operativa	0 / +70 °C (32 / 158 °F)
Monitor gráfico	128 x 64 pixeles
Medición máxima posible	999 metros / 999 pies
Tamaño (mm)	100 x 100 x 32**
Peso (g)	160

\* excluida la zona de conexión de los cables - \*\* sin tapa de protección



### **Atención**

**ALIMENTAR EXCLUSIVAMENTE CON CORRIENTE CONTINUA.**

## Notas de carácter general

El cuentametros **EV-030** debe ser utilizado para los fines descritos en este manual: accionamiento y visualización de los metros/pies de cadena desenrollados desde un molinete. Cualquier otro uso se considerará como impropio.

**La alteración del instrumento provocará la invalidación inmediata de la garantía.**

## Componentes

Componentes:

- cuentametros, guarnición y tapa de cierre;
- conector macho de diez polos con 10 contactos macho a engazar;
- sensor magnético;
- kit de soporte (soporte del sensor para molinetes de eje vertical, base de soporte, 2 tornillos de fijación y junta tórica);
- imán;
- soporte sensor para molinetes de eje horizontal;
- instrucciones de uso.

## Instalación

**En algunos modelos de torno de ancla el sensor y el imán se encuentran ya instalados (predisposición cuentametros) por lo que no es necesario efectuar las operaciones que se indican a continuación.**

### Instalación del imán en el molinete

- Se debe practicar un agujero en un resalte del barbotén de diámetro 6,5 mm (~1/4") y profundidad 8 mm (5/16"). Practicar este agujero en una zona no coincidente con el paso de la cadena.
- En el caso de molinetes de eje vertical (véase Fig. 1B), practicar el agujero en la circunferencia inferior del barbotén.
- En el caso de molinetes de eje horizontal (véase Fig. 2B), practicar el agujero en la circunferencia externa del barbotén.
- Controlar que durante la rotación del barbotén, la parte saliente del imán no golpee ni la base ni el sensor.
- Introducir el imán en el agujero por la parte metálica dejando que la parte protegida sobresalga en la medida aproximada de 2 mm. Fijar el imán utilizando un pegamento para metales (cola epoxídica bi-componente) o silicona. El pegamento utilizado debe ser resistente al ambiente marino.



## Montaje sensor magnético para molinetes de eje vertical (véanse Fig. 1A y 1B)

- Practicar en la cubierta un agujero de diámetro 4 mm (~3/16") para permitir el paso del cable del sensor.
- Fijar el elem. A del soporte, utilizando para ello los dos tornillos adjuntos, una vez posicionada la junta tórica en la parte inferior del mismo.
- Introducir el elem. B, con el sensor magnético, en el soporte A y regular su altura de manera que quede alineado con el imán fijado en el barbotén.
- Acercar el sensor de manera que quede a una distancia aproximada de 3 mm (~1/8") respecto del imán y fijarlo apretando el tornillo G1. A continuación, apretar el tornillo G2.

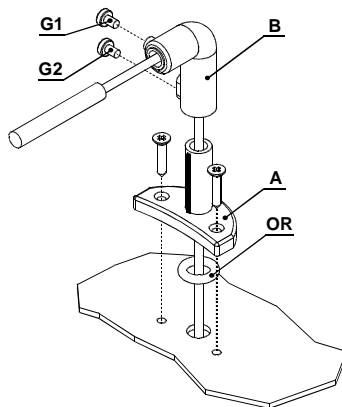

## Montaje sensor magnético para molinetes de eje horizontal

(véanse Fig. 2A, 2B y 2C)

- Practicar en la cubierta un agujero de diámetro 4 mm (~3/16") para permitir el paso del cable del sensor.
- Fijar el elem. A del soporte, utilizando para ello los dos tornillos adjuntos, una vez posicionada la junta tórica en la parte inferior del mismo.
- Mediante una sierra cortar a la medida el elem. C. El sensor debe quedar posicionado aproximadamente a 3 mm (~1/8") respecto del imán.
- Introducir el elem. C, con el sensor magnético, en el soporte A y fijarlo utilizando un pegamento para materiales plásticos (cola epoxídica bi-componente) o silicona.
- Utilizando el mismo pegamento, fijar el sensor en el elem. C.

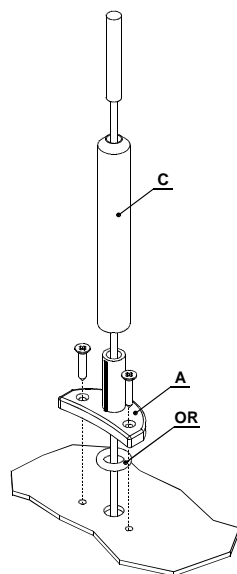

## Instalación del cuentametros

(véase esquema eléctrico)



### Atención

**DESCONECTAR SIEMPRE LA BATERÍA ANTES DE EFECTUAR LA INSTALACIÓN.**

- El cuentametros debe quedar colocado de manera que la pantalla pueda ser leída con facilidad y sin que quede expuesta a los rayos solares.
- La parte trasera del cuentametros debe estar protegida del contacto con el agua o de la humedad.
- El instrumento puede ser fijado en el panel de mando de cualquier espesor. Los tornillos de fijación deben ser autorroscantes con un diámetro de 3,5 mm (~9/64") y longitud máxima de 10 mm más el espesor del panel.
- En la parte trasera del puente de mando debe existir un espacio mínimo de 35 mm (~1"3/8). Además, debe existir un acceso para la instalación y el mantenimiento.
- En el panel de mando practicar un agujero de diámetro 30 mm (~ 1" 3/16), procediendo de la manera ilustrada, y 4 agujeros de 4 mm (~5/32") para los tornillos de fijación del cuentametros. Cortar con una tenaza los tres vástagos situados en la parte trasera del instrumento, posicionar el cuentametros y apretar los cuatro tornillos para fijarlo al panel. En caso de que en el panel de mando exista ya un agujero de 54 mm (2"1/8) no será necesario cortar los vástagos traseros.
- La guarnición debe ser colocada entre la parte delantera del panel del puente de mando y el instrumento.

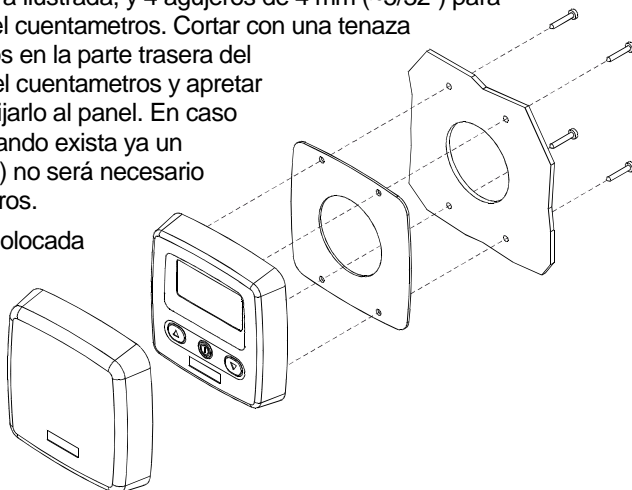

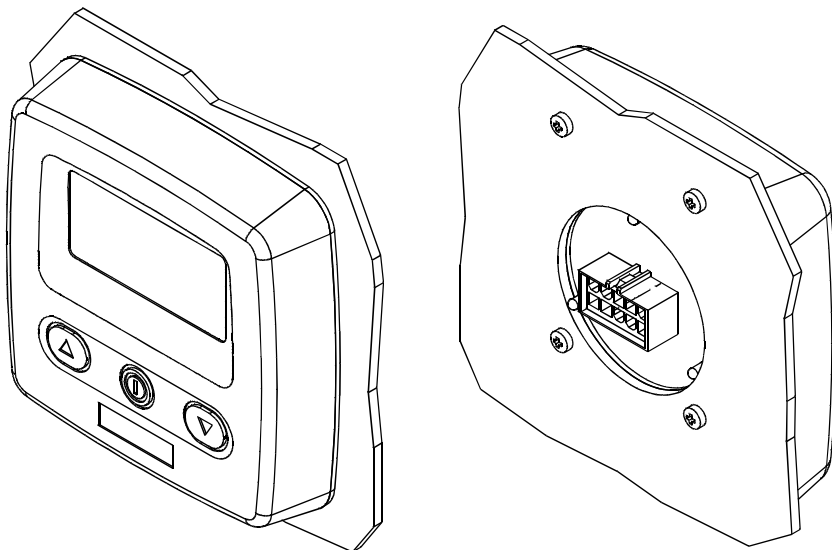

- Para efectuar la conexión eléctrica aplicar las instrucciones que aparecen en el esquema anexo. La sección mínima de los cables debe ser de 1,5 mm<sup>2</sup>.
- Instalar un fusible de protección rápido de 4 A (amperios) en el cable (+) de la batería. No utilizar para la alimentación la tensión proveniente del conjunto de baterías de los motores.
- El instrumento está conforme con lo establecido por los estándares EMC (EN55022) y debe ser posicionado a una distancia de:
  - 30 cm (~1 Ft) respecto de la brújula;
  - 50 cm (~1,5 Ft) respecto de aparatos radiorreceptores;
  - 2 metros (~6,5 Ft) respecto de aparatos radiotransmisores;
  - 2 metros (~6,5 Ft) respecto de la banda radar.

## Conexiones

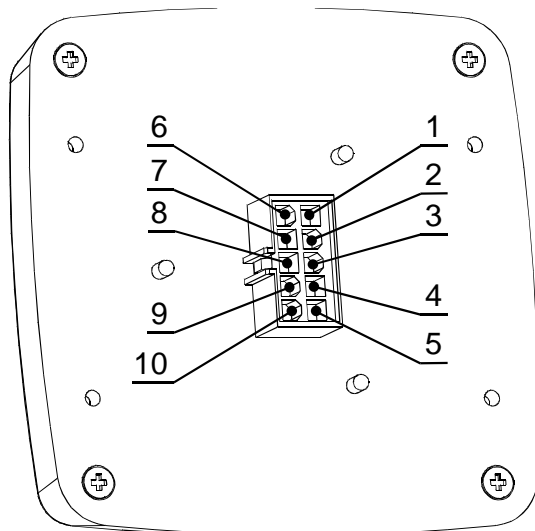

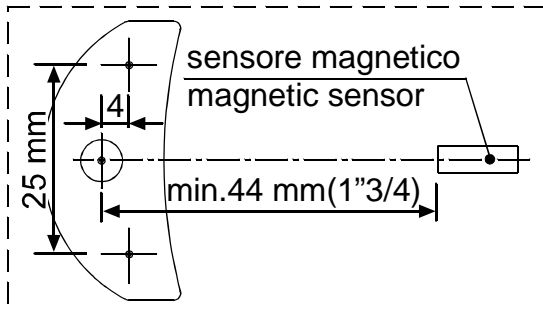
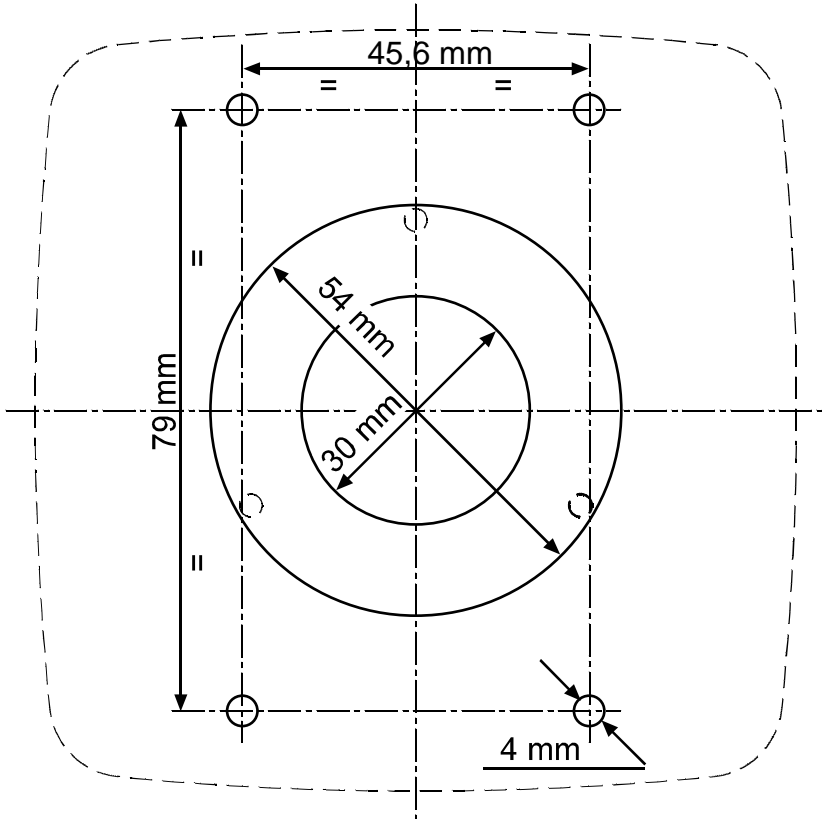

CONECTOR TRASERO DE 10 POLOS	
PIN	SEÑAL
1	+ Batería
2	
3	- Batería
4	
5	
6	Mando UP
7	Mando DOWN
8	
9	Entrada sensor Cabo_Cadena
10	Sensor magnético

### Perforación cuentametros y sensor



## Primer encendido

El cuentametros está provisto de un monitor gráfico y de tres teclas:  (ON),  (UP) y  (DOWN). Además, está presente un *zumbador* que señala la presión sobre las teclas o llama la atención del usuario respecto de situaciones particulares (activación de alarmas).

La tecla **ON** enciende el monitor y habilita las dos teclas restantes. Debe utilizarse para obtener acceso a los menús de configuración de los parámetros, para seleccionar los parámetros a modificar y para confirmar los valores incorporados. El monitor se apagará 30 segundos después del último mando dispuesto (tiempo *predeterminado* modificable, véase “Tiempo Ilum.”).

La tecla **UP** manda la subida del ancla mientras que la tecla **DOWN** la bajada. Al soltar cada tecla se interrumpirá la respectiva maniobra. Durante la configuración de los parámetros estas dos teclas permiten desplazarse en el ámbito del menú y modificar los respectivos valores.

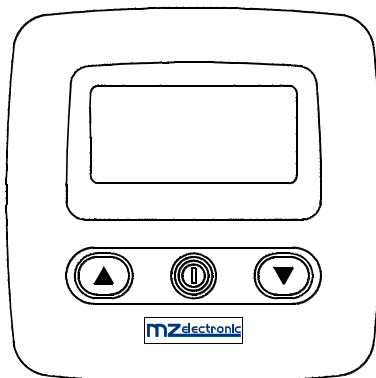

Al encenderlo, el instrumento emitirá un sonido y durante algunos segundos aparecerá la siguiente página:



Chain Counter

Una vez concluido el procedimiento de inicialización, aparecerá la página principal.

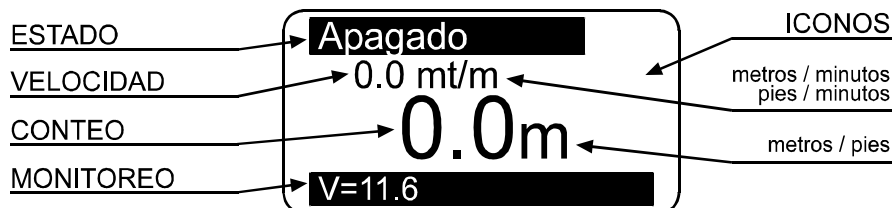

En la que:

**ESTADO:** indica el estado del instrumento así como posibles anomalías.

**VELOCIDAD:** indica la velocidad de la cadena, en subida o bajada, en metros por minuto o en pies por minuto.

**CONTEO:** indica en metros o pies la cantidad de cadena bajada.













**MONITOREO:** indica la tensión de alimentación.

**ICONOS:** es la parte del monitor en que aparecen los iconos que indican la subida o la baja del ancla además de posibles anomalías.

Al efectuar el primer encendido, el instrumento se presentará de la manera configurada en fábrica (véase tabla).

Parámetro	Valor predeterminado
Alarma Subida	3.0 metros
Auto Bajada	Off
Tiempo Iluminación	30 segundos
Unidad de medida	Metros/centímetros
Medida cadena	0.0 metros
Vuelta Molinete	33 cm
Tipo sensor	desconocido
Alarma Sonora	Si
Idioma	Italiano
Tempo Funcionamiento	0
Cabo_Cadena	Off

## Menú de configuración cuentametros

















<p>Manteniendo presionada la tecla  (ON) durante seis segundos, se encenderá el menú de configuración del instrumento. En el monitor aparecerá la siguiente página:</p>	<div style="border: 1px solid black; padding: 5px;"> <p><b>Menu</b></p> <p><b>Medida</b></p> <p>Funciones</p> <p>Ajuste Pers.</p> <p>Lenguaje</p> <p>Calibrac. Sens.</p> </div>
<p>Utilizar la tecla  (DOWN) o  (UP) para desplazarse entre las opciones del menú.</p>	<div style="border: 1px solid black; padding: 5px;"> <p><b>Menu</b></p> <p>Lenguaje</p> <p><b>Calibrac. Sens.</b></p> <p>Controles</p> <p>Salida</p> </div>
<p>Una vez elegida la opción a modificar, presionar la tecla  (ON) para confirmar la selección efectuada.</p>	
<p>Utilizar la tecla  (DOWN) o  (UP) para desplazarse entre los parámetros.</p>	
<p>Una vez elegido un parámetro, presionar la tecla  (ON) para habilitar la modificación.</p>	
<p>En función del tipo de parámetro, utilizando la tecla  (DOWN) o  (UP) será posible reducir/aumentar el valor del mismo o inhabilitar/habilitar la función.</p>	
<p>Una vez efectuada la modificación, presionar la tecla  (ON) para confirmar.</p>	
<p>Operar con la tecla  (DOWN) para situarse sobre la opción <b>Salida</b> y presionar nuevamente la tecla  (ON) para retornar al menú de configuración. El mismo procedimiento deberá utilizarse para retornar a la página principal.</p>	

















## Menú de medición





<div style="border: 1px solid black; padding: 5px; width: fit-content; margin: 0 auto;"> <div style="background-color: black; color: white; padding: 2px; display: inline-block;"><b>Medida</b></div>  <div style="display: flex; justify-content: space-between; width: 100%;"> <span><b>Res. Medida</b></span> <span>No</span> </div> <div style="display: flex; justify-content: space-between; width: 100%;"> <span>Unidad de med</span> <span>Metros</span> </div> <div style="display: flex; justify-content: space-between; width: 100%;"> <span>C. Cadena</span> <span>Off</span> </div> <div style="display: flex; justify-content: space-between; width: 100%;"> <span>Salida</span> <span></span> </div> </div>	
<p>Utilizar la tecla  (<b>DOWN</b>) o  (<b>UP</b>) para desplazarse entre los parámetros.</p>	
<p><b>Reseteo Medida</b> Poner en cero el valor de medición de la cadena (0.0).</p>	<p>Seleccionar con </p> <p> = Sí       = No</p> <p>Confirmar con </p>
<p><b>Unidad de medida</b> Se selecciona la unidad de medida:</p> <p style="text-align: center;">Pies / pulgadas Metros / centímetros</p>	<p>Seleccionar con </p> <p> = Pies       = Metros</p> <p>Confirmar con </p>
<p><b>Cabo Cadena</b> Es posible habilitar la función e incorporar el valor con el cual el sensor pasa de cabo a cadena. Valores admitidos entre 0,1 y 25,0 (metros o pies). Este valor corresponde a la longitud de la cadena. <b>Para contar con esta función se deberá montar el sensor CMCT-01 (opcional).</b></p>	<p>Seleccionar con </p> <p>Incorporar el valor con  </p> <p>Confirmar con </p>
<p><b>Salida</b> Para retornar al menú de configuración.</p>	<p>Confirmar con </p>

## Menú de alarmas y funciones









<div style="border: 1px solid black; padding: 5px; width: fit-content; margin: auto;"> <p><b>Funciones</b></p> <table style="width: 100%; border-collapse: collapse;"> <tr> <td style="border-bottom: 1px solid black;">Al. Subida</td> <td style="text-align: right;">3.0</td> </tr> <tr> <td>Auto Bajada</td> <td style="text-align: right;">Off</td> </tr> <tr> <td>Dato de Fab</td> <td style="text-align: right;">No</td> </tr> <tr> <td>Salida</td> <td></td> </tr> </table> </div>		Al. Subida	3.0	Auto Bajada	Off	Dato de Fab	No	Salida	
Al. Subida	3.0								
Auto Bajada	Off								
Dato de Fab	No								
Salida									
<p>Utilizar la tecla  (DOWN) o  (UP) para desplazarse entre los parámetros.</p>									
<p><b>Alarma Subida</b> Es posible habilitar la función y establecer la cuota a la cual el molinete se detiene; después de lo cual es posible operar sólo con el mando por impulsos. Valor programable: 1,0 / 1,5 / 2,0...5,0 (metros o pies).</p>	<p>Seleccionar con </p> <p>Incorporar el valor con  </p> <p>Confirmar con </p>								
<p><b>Auto Bajada</b> Habilita el procedimiento de bajada automática del ancla a la cota programada, con la presión (al menos durante 3 s) de las teclas  y . Valor programable: 5 / 10 / 15...40 (metros o pies).</p>	<p>Seleccionar con </p> <p>Incorporar el valor con  </p> <p>Confirmar con </p>								
<p><b>Datos de Fábrica</b> Esta función permite convocar los datos originales, incorporados en fábrica, <u>cancelando las configuraciones almacenadas</u>. <b>Usar este mando sólo en caso de programación errónea.</b></p>	<p>Seleccionar con </p> <p> = Sí       = No</p> <p>Confirmar con </p>								
<p><b>Salida</b> Para retornar al menú de configuración.</p>	<p>Confirmar con </p>								

## Menú de configuraciones







<div style="border: 1px solid black; padding: 5px; width: fit-content; margin: 0 auto;"> <p><b>Ajuste Pers.</b></p> <p><b>Contraste</b></p> <p>Iluminacion</p> <p>Tiempo Ilum.            30</p> <p>Al. Sonora                Si</p> <p>Salida</p> </div>	
<p>Utilizar la tecla  (DOWN) o  (UP) para desplazarse entre los parámetros.</p>	
<p><b>Contraste</b></p> <p>Habilitando esta función es posible activar el procedimiento de programación de contraste del monitor.</p>	<p>Seleccionar con </p> <p>Incorporar el valor con  </p> <p>Confirmar con </p>
<p><b>Iluminación</b></p> <p>Habilitando esta función es posible activar el procedimiento de programación de la intensidad luminosa del monitor.</p>	<p>Seleccionar con </p> <p>Incorporar el valor con  </p> <p>Confirmar con </p>
<p><b>Tiempo Iluminación</b></p> <p>Esta función permite programar el tiempo durante el cual el monitor permanece encendido después del último mando lanzado (valor predeterminado 30 segundos).</p>	<p>Seleccionar con </p> <p>Incorporar el valor con  </p> <p>Confirmar con </p>

<p><b>Alarma Sonora</b> Esta función permite habilitar o inhabilitar el <i>zumbador</i> (sonido emitido cada vez que se presiona una tecla).</p>	<p>Seleccionar con </p> <p> = No       = Sí</p> <p>Confirmar con </p>
<p><b>Salida</b> Para retornar al menú de configuración.</p>	<p>Confirmar con </p>





## Menú idioma

	
<p>Utilizar la tecla  (DOWN) o  (UP) para desplazarse entre los parámetros.</p>	
<p><b>Lenguaje</b> Es posible seleccionar el idioma del monitor:</p> <ul style="list-style-type: none"> <li>Italiano</li> <li>English</li> <li>Français</li> <li>Deutsch</li> <li>Español</li> </ul>	<p>Seleccionar con </p> <p>Incorporar el valor con  </p> <p>Confirmar con </p>
<p><b>Salida</b> Para retornar al menú de configuración.</p>	<p>Confirmar con </p>

## Menú de calibración sensor

<div style="border: 1px solid black; padding: 5px; width: fit-content; margin: auto;"> <p><b>Calibrac. Sens.</b></p> <p><b>Encuentra Sen</b></p> <p>Vue. Molinete      33.0</p> <p>Salida</p> </div>	
<p>Utilizar la tecla  (DOWN) o  (UP) para desplazarse entre los parámetros.</p>	
<p><b>Encuentra Sensor</b></p> <p>Esta función tiene por objeto calibrar el instrumento en función del tipo de sensor montado (Estándar o Project). La segunda pantalla indica el lapso por un período del sensor y el tipo del mismo.</p>	<p style="text-align: center;">Seleccionar con </p> <div style="border: 1px solid black; padding: 5px; width: fit-content; margin: auto;"> <p><b>Encuentra Sen.</b></p> <p>Presion Subida/Bajada para accionar el mot</p> </div>
<p>Presionar  o </p>	
<div style="border: 1px solid black; padding: 5px; width: fit-content; margin: auto;"> <p><b>Encuentra Sen.</b></p> <p>Presion Subida/Bajada para accionar el mot 0.400 sec. Std. Sensor</p> </div>	<div style="border: 1px solid black; padding: 5px; width: fit-content; margin: auto;"> <p><b>Encuentra Sen.</b></p> <p>Presion Subida/Bajada para accionar el mot 0.400 sec. Proj. Sensor</p> </div>
<p>Confirmar con </p>	

Una vez que la rutina de “Detección Sensor” ha individuado un sensor de tipo “Estándar” en lugar de “Project”, con la sucesiva entrada en el Menú “Calib. Sensor” las opciones del menú mismo se “especializan” en función del sensor encontrado.

<p align="center"><b>Menú sensor Estándar y Project serie X..</b> (sensor y magneto aplicados en el barbotín)</p> <div style="border: 1px solid black; padding: 5px; margin: 10px 0;"> <p><b>Calibrac. Sens.</b></p> <p><b>Vue. Molinete</b>      33.0</p> <p>Salida</p> </div>	<p align="center"><b>Menú sensor Project serie 1000 – 1500 – 2000 W</b> (sensor y magneto aplicados en el motor)</p> <div style="border: 1px solid black; padding: 5px; margin: 10px 0;"> <p><b>Calibrac. Sens.</b></p> <p><b>Factor Proj.</b>      57.0</p> <p>Salida</p> </div>
<p><b>Vuelta del Molinete</b> En esta línea se debe incorporar el valor de circunferencia del barbotín (en centímetros o pulgadas). Para calcular la circunferencia utilizar la <b>Tabla 1</b>. Valor programable: centímetros o pulgadas. Valor predeterminado 33 cm.</p>	<p><b>Factor Project</b> En esta línea se debe incorporar el factor de reducción. Para elegir el correcto valor que se ha de incorporar, consúltese la <b>Tabla 2</b>. Valor predeterminado 57.</p>
<p>Seleccionar con </p> <p>Incorporar el valor con  </p> <p>Confirmar con </p>	
<p><b>Salida</b> Para retornar al menú de configuración.</p>	<p>Confirmar con </p>

**Tabla 1 - Sensor Estándar y Project serie X..**  
(sensor y magneto aplicados en el barbotín)

Medida cadena	Número de muescas	Circunferencia Barbotén (cm)	Circunferencia Barbotén (pulgadas)
6 mm	9	34	13
7 mm	6	25	9
8 mm	6	28	11
	7	33*	13
	8	38	15
10 mm	5	31	12
	6	36	14
12 mm	5	36	14
	6	43	17
13 mm	6	46	18
14 mm	5	42	16
3/8" BBB	7	38	15
3/8" HT	6	37	14
5/16" HT	7	36	14
1/2" BBB	6	40	16
1/2" HT	5	40	16





\* programación del instrumento efectuada en la fábrica

**Tabla 2 - Sensor Project serie 1000 – 1500 – 2000W**  
(sensor y magneto aplicados en el motor)

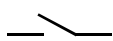

Modelo	Circunferencia Barbotén (cm)	Relación de reducción	Número de muescas	Medida cadena (mm-pulgadas)	Factor Project
Project 1000	30	1:52	6	8-5/16"HT	57*
	30	1:52	5	10 DIN 766	
	31	1:52	5	10 ISO-3/8"HT	59
	34	1:52	9	6	65
Project 1500	30	1:70	6	8-5/16"HT	43
	30	1:70	5	10 DIN 766	43
	31	1:70	5	10 ISO-3/8"HT	44
	36	1:70	5	12 ISO-13 DIN 766-7/16"HT	51
Project 2000	39	1:75	6	3/8"HT	52
	40	1:75	6	3/8"Proof Coil	53
	41	1:75	6	10 DIN 766-3/8"BBB	54
	44	1:75	7	10 ISO	58
	45	1:75	5	14 ISO	60
	46	1:75	6	12 ISO-13 DIN 766	61
	47	1:75	5	13 DIN 764	63

\* programación del instrumento efectuada en la fábrica

## Menú de verificaciones

<div style="border: 1px solid black; padding: 5px; width: fit-content; margin: 0 auto;"><p><b>Controles</b></p><p><b>Test Sensor</b></p><p>Test LCD</p><p>Version Sw            1.01</p><p>Tiempo Func.         0</p><p>Salida</p></div>	
<p>Utilizar la tecla  (DOWN) o  (UP) para desplazarse entre los parámetros.</p>	
<p><b>Test del Sensor</b></p> <p>Esta función tiene por objeto verificar el estado del sensor:</p> <p style="margin-left: 40px;">contacto abierto</p>  <p style="margin-left: 40px;">contacto cerrado</p>	<p>Seleccionar con </p> <div style="border: 1px solid black; padding: 10px; margin: 10px auto; width: 80%;"><p><b>Test Sensor</b></p></div> <div style="border: 1px solid black; padding: 10px; margin: 10px auto; width: 80%;"><p><b>Test Sensor</b></p></div> <p>Confirmar con </p>

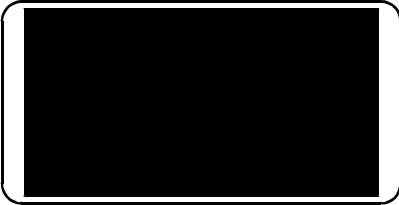

<p><b>Test LCD</b>          Esta función enciende todos los <i>pixeles</i> del monitor a fin de efectuar la verificación del mismo.</p>	<p>Seleccionar con </p>  <p>Confirmar con </p>
<p><b>Version Software</b>          Indica la versión del <i>software</i>.</p>	
<p><b>Tiempo Funcionamiento</b>          Indica las horas de funcionamiento del torno.</p>	
<p><b>Salida</b>          Para retornar al menú de configuración.</p>	<p>Confirmar con </p>

## Calibración del instrumento

Antes de utilizar el instrumento será necesario configurar los siguientes parámetros:

- elección de la unidad de medida (metros o pies);
- configuración de la función Cabo\_Cadena (**sensor CMCT-01 opcional**);

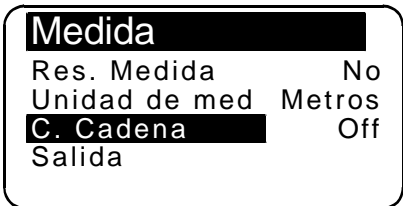

- detección del tipo de sensor (Estándar o Project);
- programación del diámetro del barbotén (valor predeterminado 33 cm) o del factor de reducción (valor predeterminado 57);

**Menú sensor Estándar y Project serie X..**

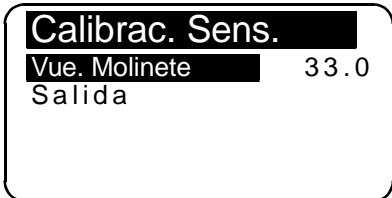

**Menú sensor Project serie 1000 – 1500 – 2000 W**

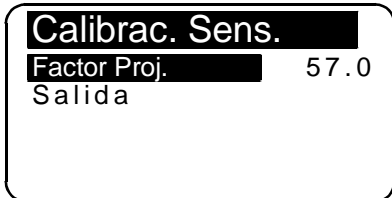

## Uso

Presionar la tecla  (**ON**) para activar los mandos e iluminar el monitor. El monitor se apaga 30 segundos después de lanzarse el último mando (tiempo predeterminado modificable, véase “Tiempo Ilum.”).

Presionando la tecla  (**UP**) se obtiene la subida del ancla.

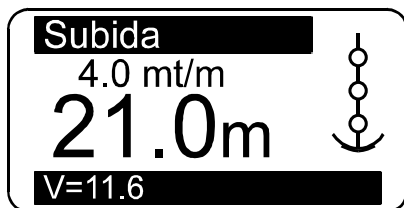

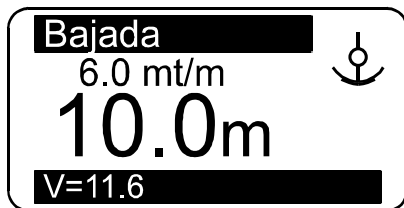

Presionando la tecla  (**DOWN**) se baja el ancla.



Al soltar cada tecla de mando (**UP** o **DOWN**) se interrumpirá la respectiva maniobra.

### Reseteo de la medición

Para poner en cero el conteo de medición presionar simultáneamente las teclas  (ON) y  (UP) al menos durante tres segundos.



La puesta en cero de la medición puede efectuarse también desde el menú **Medición**, seleccionando “**Sí**” en la línea **Reseteo Medida**.

<b>Medida</b>	
<b>Res. Medida</b>	No
Unidad de med	Metros
C. Cadena	Off
Salida	

### Bajada automática del ancla



Esta función debe ser habilitada desde el menú **Alarmas y Funciones** (esta función queda inhabilitada en fábrica).

<b>Funciones</b>	
Al. Subida	3.0
<b>Auto Bajada</b>	Off
Dato de Fab	No
Salida	

Seleccionar la línea “**Auto Bajada**” y programar la cota a la cual el ancla deberá detenerse. Después, presionar de modo simultáneo la tecla  (ON) y la tecla  (DOWN) al menos durante tres segundos. Soltar las teclas una vez que el ancla comienza a bajar.

**En todo caso, por razones de seguridad, será posible interrumpir la bajada automática presionando una cualquiera de las teclas del instrumento.**

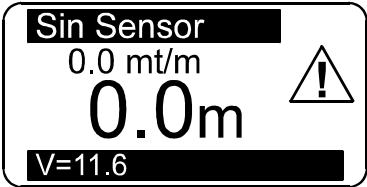
## Anomalías de funcionamiento

SEÑAL	CAUSA	REMEDIO
 <p>Sin Sensor 0.0 mt/m <b>0.0m</b> V=11.6</p>	<p>Mientras se mantiene presionada la tecla <b>UP</b> o <b>DOWN</b> el instrumento no recibe ninguna señal proveniente del sensor magnético durante un lapso superior a 5 segundos.</p>	<p>Controlar las conexiones eléctricas del sensor.</p> <p>Controlar el estado del sensor y sustituirlo en caso de estar averiado.</p> <p>Controlar la posición del sensor, del imán en el barbotén y la distancia entre ambos (3 mm).</p> <p>Controlar el funcionamiento del sistema eléctrico o del molinete.</p>
 <p>Tension Baja 0.0 mt/m <b>0.0m</b> V=7.9</p>	<p>La tensión de alimentación del instrumento es inferior a 10 V.</p>	<p>Controlar el nivel de carga de la batería o el funcionamiento del sistema eléctrico.</p>

## Garantía

Nuestros artículos están garantizados contra eventuales defectos de fabricación pro 2 años a partir de la fecha de compra (servirá de constancia el recibo fiscal u otra prueba de compra). No están incluidas en la garantía: averías y roturas causadas por el transporte, intervenciones efectuadas por problemas causados por errónea instalación, averías causadas por uso inapropiado del aparato. La garantía caduca en la hipótesis de mantenimiento o reparaciones efectuadas por personas no autorizadas por la empresa o ejecutadas con aplicación de repuestos no originales. La garantía no prevé en ningún caso la completa sustitución del aparato. La garantía se refiere exclusivamente a la sustitución de repuestos defectuosos y correspondiente mano de obra. No comprende el transporte o los gastos de traslado. El Cliente no podrá pretender ningún reembolso por los gastos sostenido.

# SCHEMA ELETTRICO / ELECTRICAL DRAWING

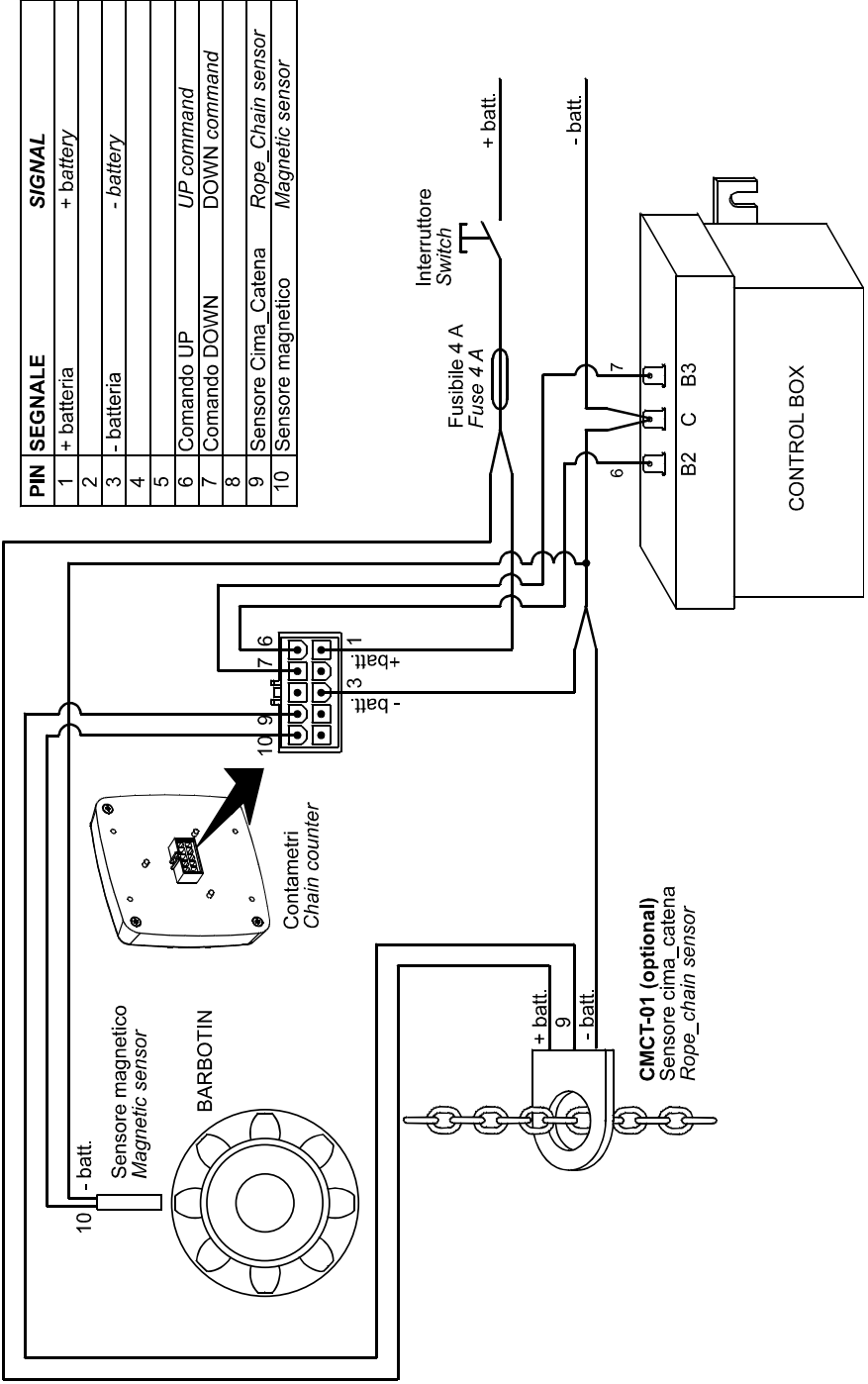





MZ ELECTRONIC S.R.L.

Via Bainsizza, 2

20052 MONZA (MI)

Tel.+39 039 2148126 - Fax. +39 039 2146244

[www.mzelectronic.com](http://www.mzelectronic.com)

e-mail:[info@mzelectronic.com](mailto:info@mzelectronic.com)