



Verricello ad asse orizzontale in alluminio anticorrosivo anodizzato con campana in acciaio INOX. Il RAJA può usare catena dal 10mm al 14mm di diametro. Con differenti motorizzazioni è suggerito per barche fino ai 26m. Disponibile in differenti configurazioni di campane e barbotin. Per la versione desiderata consultare la tabella configurazione verricelli.

Anticorrosive aluminium horizontal axis windlass. Whit stainless steel drum The RAJA can use chains from 10 mm to 14 mm in diameter. With different drives and recommended for boats up to 26m. Available in different drum and gypsy configurations. For the version see the windlass configuration table.



RELÈ



IDRAULICO

Possibilità Verniciatura Bianca
White Painting Option

CARATTERISTICHE	POTENZA MOTORE <i>ELECTRIC MOTOR</i>	2300W	2700W	3600W	HY
	TENSIONE DI ALIMENTAZIONE <i>MOTOR SUPPLY VOLTAGE</i>	24V	24V	230V/400V	N/A
TIRO ISTANTANEO MASSIMO <i>MAXIMUM PULL</i>	2800 Kg	3000KG	3200 Kg	700 Kg	
CARICO LAVORO AL SOLLEVAMENTO <i>LIFT WORKING LOAD</i>	520 Kg	590 Kg	700 Kg	700 Kg	
VELOCITÀ DI RECUPERO A CARICO <i>LINE SPEED</i>	12 mt/min	12 mt/min	12 mt/min	12 mt/min	
ASSORBIMENTO MEDIO <i>CURRENT ABSORPTION</i>	120 A	150 A	N/A	N/A	
PESO (CON CAMPANA) <i>WEIGHT (WITH DRUM)</i>	←————— 55 to 70 Kg —————→				

CATENA	Barbotin / Gypsy	10mm		10 DIN 766		12mm			14mm	1/2" HT	14 C.T.	12,5 C.T.
	Catena supportata <i>Chain supported</i>		10mm ISO4565	3/8" G4	10mm DIN766	3/8" BBB	12mm ISO	13mm DIN 766	7/16" G4	14mm ISO	1/2" HT	14 Stud link

2300	A	B	C	D	E	F	G	H
	632	500	400	280	210	165	260	240

2700	A	B	C	D	E	F	G	H
	632	500	400	280	210	165	260	240

3600AC	A	B	C	D	E	F	G	H
	632	500	400	280	210	165	260	240

HY	A	B	C	D	E	F	G	H
	632	500	400	280	210	165	260	240

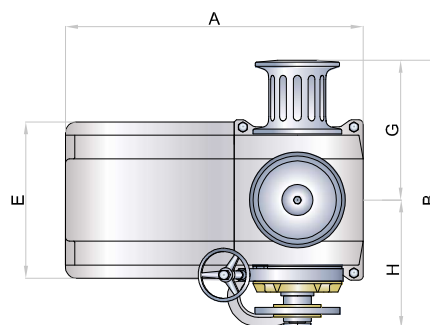
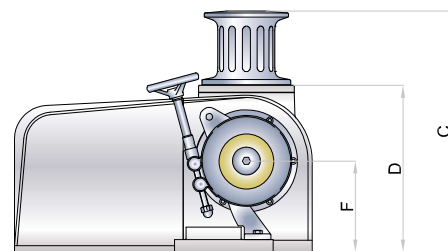

Tutte le misure indicate sono in mm
All sizes are in mm