

UNIQUE DESIGN

The Gebo Air Suction Ventilators are the perfect blend of form and function.

This unique Gebo-developed design provides efficient engine compartment air management through a powerful air suction unit that requires no power source whatsoever other than the air movement outside of the boat. There are no fans, no motors, and virtually no maintenance.

When the craft is in motion, the unit simply extracts air from the engine compartment and replaces it with fresh air from outside the craft.

CLEAN AIR AND CLEAN LINES TOO

To preserve the clean lines of your design, Gebo Air Suction Ventilators are manufactured in exactly the same style and extrusions, and in the same wide choice of frame colors and finishes, as Gebo portlights.

KEEPS WATER OUT

A special dorade box system, supplied as standard, ensures that any water that collects within the air suction mechanism can be directed out of the unit to the outside of the boat.

CHOICE OF TWO FITTING SYSTEMS

Two different systems are available: with inner rim for a fast, neat finish using the unique Gebo labour-saving clamp system; or for screwing directly to the hull without inner rim.





Watertight design
Same style
as Gebo
portlights

Air Suction Ventilators should be fitted to a flat surface with a maximum tolerance of 1 mm.

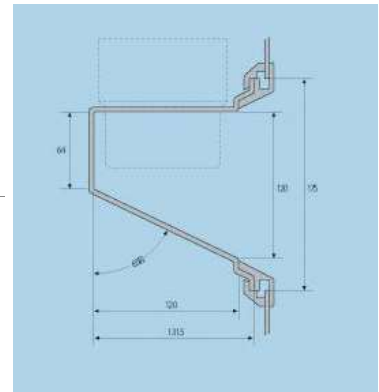

600x175mm

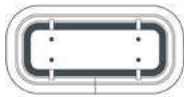

375x175mm

Article no.	System	Version	Cut-out size LxW mm	Radius mm
81.60.01.00	Visible Screwed	white coated	600x175	88
81.60.02.00	Visible Screwed	blank anodised	600x175	88
81.60.03.00	Visible Screwed	black coated	600x175	88
81.60.50.00	Clamp System	blank anodised	600x175	88
81.60.51.00	Clamp System	white coated	600x175	88
81.60.53.00	Clamp System	black coated	600x175	88
81.60.00.75	Clamp System	blank anodised	375x175	88
81.60.00.01	Clamp System	blank anodised	375x175	56